

**Code changes  
based on the  
2020 NEC®**



# Table of contents

## Introduction

Fault current and equipment ratings	<a href="#">3-12</a>
Fault current	<a href="#">4</a>
Available fault current	<a href="#">4</a>
Interrupting rating	<a href="#">4</a>
Equipment short-circuit rating (SCCR)	<a href="#">5</a>
Marking and documenting requirements	<a href="#">5-6</a>
Two to six service disconnects and service terminal barriers	<a href="#">7</a>
Arc energy reduction (incident energy and arc flash hazards)	<a href="#">8</a>
Reconditioned equipment	<a href="#">8-9</a>
Selective coordination	
NEC Selective coordination requirements	<a href="#">9-10</a>
Achieving selective coordination	<a href="#">10</a>
Fuse selectivity amp rating ratios	<a href="#">11-12</a>

## Article 100 Definitions

Coordination, selective	<a href="#">13</a>
Fault current	<a href="#">14</a>
Available fault current	<a href="#">15-16</a>
Reconditioned	<a href="#">17</a>

## Article 110 Requirements for electrical installations

110.24 Available fault current	<a href="#">18-19</a>
--------------------------------	-----------------------

## Article 230 Services

230.46 Spliced and tapped conductors	<a href="#">20</a>
230.62(C) Barriers	<a href="#">21</a>
230.71(B) Two to six service disconnecting means	<a href="#">22-23</a>
230.85 Emergency disconnect(s)	<a href="#">24</a>

## Article 240 Overcurrent protection

240.40 Disconnecting means for fuses	<a href="#">25</a>
240.62 Reconditioned equipment	<a href="#">26</a>
240.67 Arc energy reduction	<a href="#">27-28</a>
240.86 Series rating	<a href="#">29-30</a>
240.87 Arc energy reduction	<a href="#">31</a>
240.88 Reconditioned equipment	<a href="#">32</a>
240.102 Reconditioned equipment	<a href="#">33</a>

## Article 408 Switchboards, switchgear, and panelboards

408.6 Short-circuit current rating	<a href="#">34-35</a>
------------------------------------	-----------------------

## Article 409 Industrial control panels

409.22 Short-circuit current rating	<a href="#">36-37</a>
-------------------------------------	-----------------------

## Article 430 Motors, motor circuits, and controllers

430.2 Definition, 430.32(A)(2), 430.32(B)(2)	<a href="#">38</a>
430.98 Marking(A) motor control centers and	
430.99 Available fault current	<a href="#">39</a>

## Article 440 Air-conditioning and refrigeration equipment

440.10 Short-circuit current rating	<a href="#">40</a>
-------------------------------------	--------------------

## Article 590 Temporary installations

590.8 Overcurrent protective devices	<a href="#">41-42</a>
--------------------------------------	-----------------------

## Article 620 Elevators, dumbwaiters, escalators, moving walks, platform lifts, and stairway chairlifts

620.51 Disconnecting means	<a href="#">43</a>
620.62 Selective coordination	<a href="#">44-45</a>
620.65 Signage	<a href="#">46</a>

## Article 645 Information technology equipment

645.27 Selective coordination	<a href="#">47</a>
-------------------------------	--------------------

## Article 670 Industrial machinery

670.5 Short-circuit current rating	<a href="#">48</a>
------------------------------------	--------------------

## Article 695 Fire pumps

695.3(C)(3) Selective coordination	<a href="#">49</a>
------------------------------------	--------------------

## Article 700 Emergency systems

700.4 Capacity and rating, (A) and (B)	<a href="#">50</a>
700.32 Selective coordination	<a href="#">51-52</a>

## Article 701 Legally required standby systems

701.4 Capacity and rating, (A) and (B)	<a href="#">53</a>
701.31 Ground fault protection of equipment	<a href="#">54</a>
701.32 Selective coordination	<a href="#">55</a>

## Article 702 Optional standby systems

702.4 Capacity and rating, (A) available fault current	<a href="#">56</a>
--	--------------------

## Article 705 Interconnected electric power production sources

705.11 Supply-side source connections (C)	<a href="#">57-58</a>
---	-----------------------

## Article 708 Critical operations power systems (COPS)

708.54 Selective coordination	<a href="#">59</a>
-------------------------------	--------------------

## Bussmann series products

<a href="#">60</a>
--------------------

# Introduction

## What you'll find in this handbook

This handbook highlights the 2020 NEC changes pertaining to circuit protection. Please refer to the Selecting Protective Devices (SPD) handbook (publication No. 3002), also based on the 2020 NEC, for more information and further explanations.

Quik-Spec Coordination Panelboard

# Introduction

## Fault current and equipment ratings

The threat of short-circuit incidents and the effects these incidents may have on safety due to inadequate electric equipment ratings, result in numerous public inputs, public comments, and NEC revisions. In the 2020 edition and previous NEC editions, significant revisions have been made to improve terminology and add more prescriptive requirements for establishing processes to verify overcurrent protective device interrupting ratings and equipment short-circuit current ratings are adequate at the point of installation.

The Fault Current Working Group which was formed to support the Correlating Committee's Usability Task Group analyzed the usage of "fault current," "short-circuit current," "available short-circuit current," "available fault current," "maximum available short-circuit current," "maximum available fault current" and other terms. During the 2020 NEC process, this Working Group submitted many public inputs (PIs) throughout the NEC to achieve consistency of terms as an objective. Individual Technical Committees considered these PIs.

## Fault current

Overcurrent and overload have been defined in the NEC for some time. However, the definition for "fault current" is new. Prior to the 2020 NEC, fault current and short-circuit current were used interchangeably but neither were defined. With the 2020 NEC changes, the proper term is fault current, and it is defined.

Fault current flows when a short-circuit condition occurs on an energized circuit. A practical understanding when a short-circuit condition occurs is that fault current leaves the normal circuit conduction path. In contrast, during an overload condition, the current stays within the normal conduction path.

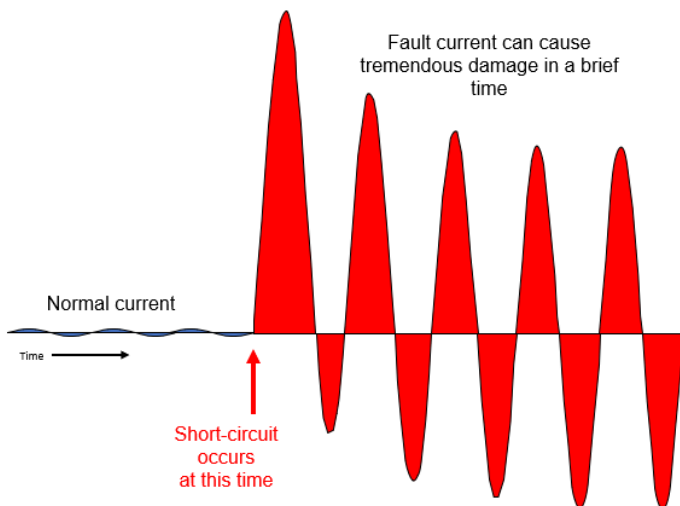

## Available fault current

Another significant change is the new definition "available fault current," also prompted by public input by the Fault Current Working Group. The intent is for "available fault current" to be used throughout the NEC rather than such terms as "available short-circuit current," "maximum available short-circuit current," and "maximum available fault current." As a result, there are many 2020 NEC changes incorporating this newly defined term.

The definition for available fault current includes an accompanying Informational Note Figure 100.1, which provides an illustrative example of the proper use of the terms available fault current, overcurrent protective device interrupting rating, and short-circuit current rating.

There are many requirements in the NEC in which the available fault current must be determined to ensure circuit breakers and fuses have sufficient interrupting ratings (110.9), devices and assemblies have sufficient short-circuit current ratings (110.10 plus many other sections), overcurrent protective devices provide selective coordination (700.32 and many more sections). Now, the terms available fault current, short-circuit current rating, interrupting rating and selective coordination are all defined in the NEC. This should help in the proper interpretation and compliance of the many requirements for these items in the NEC.

## Interrupting rating

The available fault current must be determined, so at the point of installation of each circuit breaker or fuse, their interrupting rating is equal to or greater than the available fault current, per 110.9. 240.86 permits a circuit breaker to be installed where the available fault current at its line terminals exceeds its interrupting rating where protected by supply side fuses or circuit breaker in accordance with 240.86 and where there are markings per 110.22. The 2020 NEC edition has no changes to 110.9. 240.86 has changes for improved clarity.

Failure to install overcurrent protective devices having an interrupting rating adequate for the available fault current can result in catastrophic, violent explosions which are a serious fire and shock hazard. In addition, if a person is near the equipment in which an overcurrent protective device fails while trying to interrupt a fault current beyond its interrupting rating, the person maybe subject to arc flash and arc blast hazards including high speed projectiles from the exploding equipment.

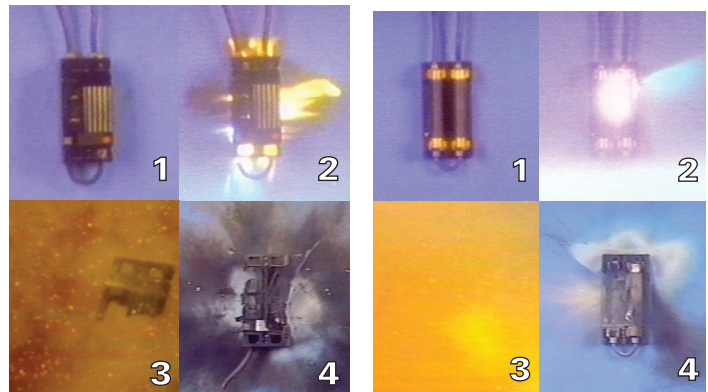

A circuit breaker misapplied beyond its interrupting rating.

A fuse misapplied beyond its interrupting rating.

# Introduction

## Equipment short-circuit current rating (SCCR)

Similarly, the available fault current must be determined so at the point of installation of each electrical device, such as motor starter, contactor, power distribution block etc., or each complete assembly, such as panelboards, MCCs, industrial control panel, etc., has a short-circuit current rating (SCCR) equal to or greater than the available fault current, per 110.10.

Installing electrical equipment where its SCCR is less than the available fault current creates serious safety hazards. Product standard SCCR testing and evaluation criteria are most often performed with the enclosure doors closed and latched, and with the fault occurring external to the enclosure. The safety hazards may include:

- Shock: The enclosure becomes energized from conductors pulling out of their terminations or device destruction occurring within the enclosure.
- Fire: The explosive power of the internal devices failing causes the closed and latched door to become ajar and spew flame and molten metal to the exterior. This is a fire hazard to both the facility and personnel.
- Projectile (shrapnel): The enclosure door may blow open or off with fire and failing device debris (shrapnel) shooting out. In laboratory tests, equipment SCCR failures have resulted in enclosure doors explosively blowing off and flying up to 100 feet away. Additionally, the shrapnel, from the rapid failure of internal devices, can be ejected at speeds up to 700 miles per hour.

Note: Even if electrical equipment is installed with the proper SCCR, there may remain shock, arc flash, and arc blast hazards for workers performing work on energized equipment with the enclosure door open.

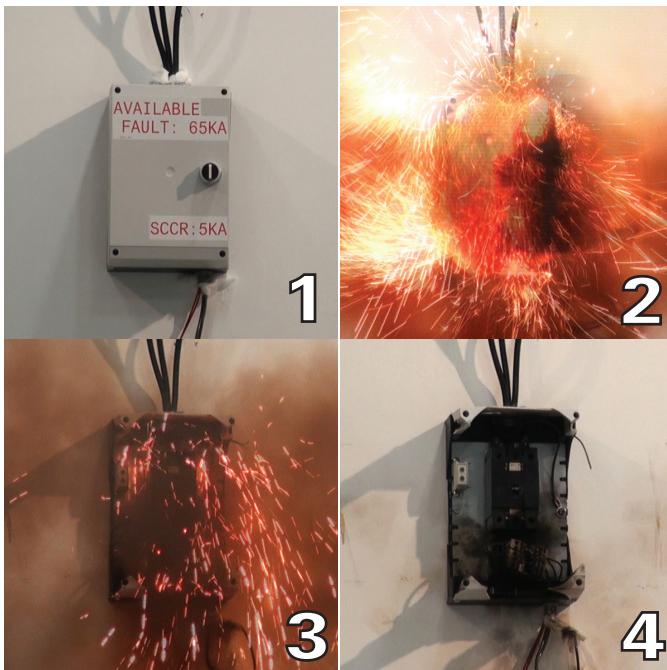

Fault currents release tremendous amounts of destructive energy and magnetic force. Selecting the correct overcurrent protective device can help ensure they do not result in a short-circuit event like the one shown above.

## Marking and documenting requirements

110.9 requiring proper overcurrent protective device interrupting rating and 110.10 requiring proper device and assembly short-circuit current rating are long standing requirements located in NEC Chapter 1 General. There are numerous other more prescriptive requirements that complement 110.9 and 110.10 throughout the NEC.

240.60(C) and 240.83(C) are long standing interrupting rating marking requirements for fuses and circuit breakers, respectively.

110.24(A), which has a new informational note about available fault current, interrupting rating and short-circuit current ratings in the 2020 NEC, requires service equipment, in other than dwelling units and some industrial installations, to be field marked with the available fault current and the date of the calculation. The available fault current calculations must be documented and made available to various disciplines involved in the design through the operation of the system. With this information, the Authority Having Jurisdiction (AHJ) can more easily verify 110.9 interrupting rating and 110.10 short-circuit current rating compliance for the service equipment. This requirement is not a burden since the specifier/purchaser of the service equipment typically needs to know the available fault current in order to acquire service equipment that complies with 110.9 and 110.10. Having these safety requirements help ensure important overcurrent protective device interrupting ratings and equipment short-circuit current ratings are applied properly.

110.24 first entered the NEC in the 2011 edition. It was an important milestone because to comply usually involves determining the available fault current that the utility can deliver, such as at the secondary of a utility transformer. In addition, this information is necessary, where the available fault current is to be calculated at other points on the load side of the service equipment.

408.6 is a significant new section which requires all panelboards, switchboards, and switchgear to have a short-circuit current rating equal to, or greater than, the available fault current at the point of installation. In addition, these assemblies, other than at dwelling units, must be marked with the available fault current and the date of the calculation.

For years, industrial control panels were a challenge to determine if they complied with 110.10 for proper short-circuit current rating. It is not cost effective to have industrial control panels tested and evaluated at a high power testing lab to determine short-circuit current ratings because typically the volumes for a specific configuration of industrial control panel is one or a few units. UL 508A Industrial Control Panel product standard, first edition published in 2001, has an analysis method, Supplement SB, which the equipment builder can use, in lieu of testing, to determine the short-circuit current rating of their industrial control panels.

The 2005 NEC was the first edition via 409.110 to require industrial control panels, that have power circuit components, to be marked with their short-circuit current rating. If an industrial control panel is marked with its SCCR:

- 409.22(B) requires the available fault current and the date the calculation was performed to be documented and made available to those authorized to inspect, install, and maintain the installation.
- 409.22(A) does not permit installing an industrial control panel where its marked short-circuit current rating is not equal to or greater than the available fault current.

# Introduction

## Marking and documenting requirements (cont.)

The following are examples of NEC requirements which complement 110.9 and 110.10 with more prescriptive requirements entailing one or more of the following:

- Marking equipment with short-circuit current ratings
- Marking or documenting the available fault current at the equipment point of installation
- Having the available fault current at equipment accessible to authorized inspectors, installers, maintainers, etc.
- Not permitting the installation of equipment unless the short-circuit current rating is equal to or greater than the available fault current.

The table below illustrates a listing of some of the many short-circuit current rating requirements in the NEC.

## Significant NEC SCCR requirements

Equipment type	Mark SCCR	Available fault current	SCCR must be equal to or greater than available fault current
	<ul style="list-style-type: none"> <li>• NEC section</li> <li>• UL product standard SCCR marking required</li> </ul>	<ul style="list-style-type: none"> <li>• NEC section</li> <li>• Field mark and/or document</li> <li>• Make available to inspector (AHJ) and possibly others</li> </ul>	<ul style="list-style-type: none"> <li>• NEC section</li> <li>• Not permitted to install equipment if SCCR is less than the available fault current</li> <li>• Essentially 110.10 and 110.3(B)</li> </ul>
Service entrance equipment	UL 67 panelboards UL 891 switchboards UL 1558 switchgear	110.24 Field mark Document	110.10
All panelboards, switchboards, and switchgear	408.6 UL 67 panelboards UL 891 switchboards UL 1558 switchgear	408.6 Field mark	408.6 SCCR not less than available fault current
Industrial control panel	409.110(4) UL 508A	409.22(B) Document	409.22(A)
Motor controller	430.8 UL 508 UL 508C UL 61800-5-1	—	110.10
Adjustable speed drive (circuits with power conversion equipment)	430.130(A)(4) <sup>2</sup> UL 508C UL 61800-5-1	—	110.10
Motor control center	430.98 UL 845	430.99 Document	110.10
Air conditioning and refrigeration equipment	440.4(B) UL 1995 UL 508A	440.10(B) Document	440.10(A)
Elevator control panel	620.16(A) UL 508A	620.51(D)(2) Field mark	620.16(B)
Industrial machinery	670.3(A)(4) NFPA 79 UL 508A	670.5(2) Field mark	670.5(1)
Transfer equipment in emergency systems	700.5(E) Field mark <sup>3</sup> UL 1008	—	110.10
Transfer equipment in legally required standby systems	701.5(D) Field mark <sup>3</sup> UL 1008	—	110.10
Transfer equipment in optional standby systems	702.5 Field mark <sup>3</sup> UL 1008 UL 67 UL 98	—	110.10
Transfer equipment in critical operations power systems	708.24 Field mark <sup>3</sup> UL 1008	—	110.10

1. This is a high level summary. Reference the 2020 NEC for complete requirements and exceptions.

2. The 430.130(A)(4) requirement pertains to listed adjustable speed drives. UL 508C and UL 61800-5-1 require, when high speed fuses or MCPs are used in lieu of branch circuit overcurrent protective devices, the adjustable speed drive must be marked with the specific fuse manufacturer and its high speed fuse model number or MCP manufacturer and its MCP model number.

3. The product standards for transfer switches require the equipment to be factory marked with the SCCR. Typically listed transfer switches are factory marked with several SCCR options, each based on different OCPD type and ampere rating/settings. This requires that the transfer equipment exterior enclosure be field marked with the SCCR based on which factory marked SCCR option the installation represents; which is dependent on the OCPD type and ampere rating/settings used for the specific installation.

# Introduction

## Two to six service disconnects and service terminal barriers

Significant revisions are made to 230.71 concerning the requirement for the maximum number of service disconnects. The revised text is more prescriptive for the circumstances permitting two to six service disconnects. In addition, the new 230.62(C) requires barriers to be placed in service equipment to avoid inadvertent contact by service or maintenance personnel with service terminals or uninsulated, ungrounded service busbar. The 2017 NEC 408.3(A)(2) requiring service panelboards, switchboards, and switchgear to have barriers has been deleted since the new 230.62(C) serves the same purpose and is broader in that it encompasses all types of service equipment. The combination of 230.71 and 230.62(C) results in safer work conditions for service and maintenance personnel who must work on service equipment.

230.71(B) provides design alternatives by permitting two to six service disconnecting means. Benefits:

- Eliminates a single large ampere rated service disconnecting means
- For solidly grounded wye systems of more than 150 volts line-to-ground and not exceeding 1000 volts phase-to-phase:
  - where a single service disconnect design of 1000A or greater requires ground fault protection of equipment (GFPE) per 230.95,
  - a two to six service disconnect design will not require GFPE if the service disconnects are less than 1000A.
- May help reduce arc flash incident energy versus one large ampere rated service disconnect. Using multiple, lower ampere rated service disconnects may also avoid requirements for arc energy reduction technologies required for fuses and circuit breakers rated 1200A or higher in 240.67 and 240.87.
- May increase power reliability

See illustration below and more discussion on the topic in this publication under 230.71(B) change.

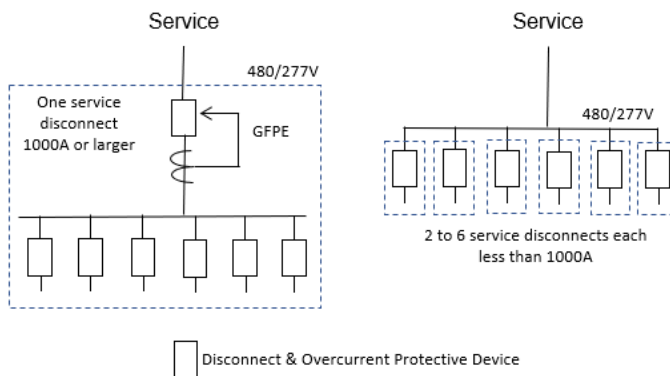

Some designers use the 230.71(B) two to six service disconnecting means design option to provide better power reliability for the normal source path supplying power to emergency systems and legally required standby systems. The more stringent new assembly requirements for 230.71(B) improve the reliability even more.

In many cases, the two to six service disconnect design option can be used to provide:

1. One service disconnect for the normal source supplying the emergency system
2. One service disconnect for the normal source supplying the legally required standby system

Separate service disconnects provide higher reliability than supplying these critical systems from a circuit that also supplies the normal system loads as well as the emergency system and legally required standby system.

For power reliability reasons, the alternate source for emergency systems and legally required standby systems are not required to have GFPE per 700.31 and 701.31, respectively. See discussions in this publication for 701.31 change. In addition, for 480/277V solidly grounded wye systems, separate service disconnects for the emergency system and legally required standby system will usually be less than 1000A, so GFPE is not required for these separate service disconnects (reference 230.95). This also increases the reliability for the power being supplied to the emergency systems and legally required standby systems. See illustration below.

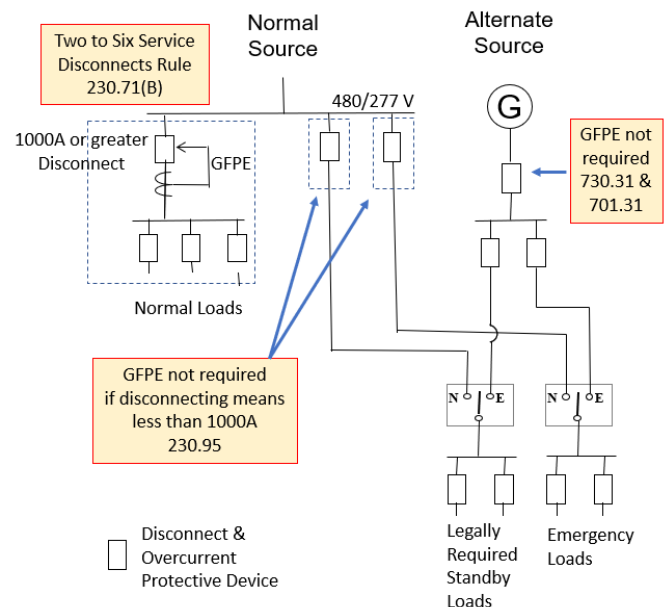

# Introduction

## Arc energy reduction (incident energy and arc flash hazards)

Understanding what incident energy levels are at various locations in an electrical distribution system is important for electrical safe work practices. It was NEC 2011 that introduced requirements for incident energy reduction for specific size and type of overcurrent protective devices. These requirements have changed since their first introduction and expanded considerably, impacting more locations within the power distribution system. The latest NEC 2020 changes recognize the importance and impact of both current and time on incident energy and how this relationship relates to achieving the goals that sections 240.67 and 240.87 have in this regard.

The new changes in 240.67 and 240.87 seek documentation that the arcing currents are in a specific region of the OCPD time-current characteristic curves or of a value high enough to activate the arc reduction methods employed when required. These changes also seek to demonstrate the technology is functional upon installation through mandatory performance testing of the arc energy reduction system installed as required by 240.67 and 240.87. It is both practical and feasible to require such testing at the time of installation. The inclusion of performance testing criteria is not new to the NEC. For instance, mandatory performance testing is required when installing ground fault protection of equipment per 210.13, 215.10 and 230.95. Acceptance testing is considered part of the installation. There are no requirements to ensure GFPE protection is set to a level that exceeds the available ground fault current at that point in the system.

Another key area of change is mandatory text that only qualified persons perform the performance testing of these arc reduction solutions. This is a critical factor as the arc reduction technologies can be more complicated than GFPE. The new NEC language specifically included the importance of the manufacturer's instructions. There are technologies that will require special test configurations and equipment to ensure proper tests are conducted to verify the arc reduction solution performs as intended.

See the 240.67 and 240.87 change discussions in this publication.



3-phase arcing fault current interrupted in six cycles.

Same magnitude 3-phase arcing fault current as in test on the left, but current interrupted in ½ cycle.

## Reconditioned equipment

Electrical equipment and components deliver power that we use safely every day because we pay attention to details like when and if equipment can be refurbished or reconditioned or if equipment must be replaced. Electrical professionals understand the capabilities of electricity when things go wrong in a power system. The electrical equipment installed must perform its duties safely and to do that, the quality of that equipment is critical. The steps that the NEC has taken regarding reconditioned and refurbished equipment are intended to increase safety.

Outside of a reference to reconditioned X-Rays (517.75) which has been a part of Article 517 since at least NEC 1968 for Health Care Facilities, the NEC has been silent on the topic of reconditioned equipment. NEC 2017 changed that by adding a new second level sub-division (2) titled "Reconditioned Equipment" to Section 110.21(A), "Equipment Markings". This new section provided specific marking requirements for reconditioned equipment. As per NEC 2017 and earlier NEC edition requirements, reconditioned equipment must be marked with the name, trademark, or other descriptive marking by which the organization responsible for reconditioning the electrical equipment can be identified, along with the date of reconditioning.

This 2017 NEC section also requires that reconditioned equipment be identified as "reconditioned" and there is a brief mention of the listing requirements for this equipment. These marking requirements add transparency for all involved.

NEC 2017 took the initial step forward on the topic of reconditioned equipment, but as usual, changes of this magnitude generated industry dialog that drove more public inputs and comments for the development of NEC 2020.

The NEMA policy on refurbished equipment was a key reference for each of the NEC code making panels as they deliberated on their changes for NEC 2020.

A total of 18 sections of the NEC spanning 15 Articles were added and/or modified to include new requirements. These sections can be separated into a few key areas including the following:

1. General requirements
2. Equipment which is NOT permitted to be reconditioned
3. Equipment which IS permitted to be reconditioned

### 1. General requirements

Two key changes in the NEC included the addition of a definition for reconditioned and additional changes to marking requirements which were added as part of NEC 2017. Terminology is important when interpreting and trying to understand any new requirements in the NEC. The NEC anticipated this, bringing forth a definition to Article 100 to help the users of the NEC understand what is meant by the word "Reconditioned".



# Introduction

## Reconditioned equipment (cont.)

### 2. NOT permitted to be reconditioned

Here is the list of equipment that NEC 2020 clarifies that cannot be reconditioned.

- Equipment that provides ground-fault circuit-interrupter protection for personnel (210.15)
- Equipment that provides arc-fault circuit-interrupter protection (210.15)
- Equipment that provides ground-fault protection of equipment (210.15)
- Low-voltage fuseholders (240.62)
- Low-voltage nonrenewable fuses (240.62)
- Molded-case circuit breakers (240.88)
- Low-voltage power circuit breaker electronic trip units (240.88)
- Medium-voltage fuseholders (240.102)
- Medium-voltage nonrenewable fuses (240.102)
- Receptacles (406.3)
- Attachment plugs, cord connectors, and flanged surface devices (406.7)
- Panelboards (408.8)
- Luminaires, lampholders, and retrofit kits (410.7)
- Listed low-voltage lighting systems or a lighting system assembled from listed parts (411.4)
- Fire pump controllers and transfer switches (695.10)
- Automatic transfer switches (700.5, 701.5, 702.5, 708.24)

### 3. Permitted to be reconditioned

When there is no code requirement that prohibits reconditioning, reconditioning is permitted. In some areas of NEC 2020, equipment was identified as being able to be reconditioned and a little more information was provided. The following sections have language permitting reconditioning:

- Low- and medium-voltage power circuit breakers (240.88)
- High-voltage circuit breakers (240.88)
- Electromechanical protective relays and current transformers (240.88)
- Switchboards and switchgear, or sections of switchboards or switchgear (410.7)
- Switchgear, or sections of switchgear, within the scope of Article 490

## Selective coordination

### NEC selective coordination requirements

Selective coordination of overcurrent protective devices is important to avoid unnecessary power outage to loads. See the Article 100 of the NEC definition:

*“Coordination, Selective (Selective Coordination). Localization of an overcurrent condition to restrict outages to the circuit or equipment affected, accomplished by the selection and installation of overcurrent protective devices and their ratings or settings for the full range of available overcurrents, from overload to the available fault current, and for the full range of overcurrent protective device opening times associated with those overcurrents.”*

## NEC selective coordination requirements (cont.)

In addition to the Article 100 selective coordination definition (which is revised), there are several NEC sections in which selective coordination is required, including:

- 620.62 Elevators, Dumbwaiters, Escalators, Moving Walks, Platform Lifts, and Stairway Chairlifts (revised)
- 620.65 Elevators, Dumbwaiters, Escalators, Moving Walks, Platform Lifts, and Stairway Chairlifts (revised)
- 645.27 Information Technology Equipment, Critical Operations Data Systems (revised)
- 695.3(C)(3) Fire Pumps, Multibuilding Campus-Style Complexes (revised)
- 700.10(B)(5)(b)(ii)
- 700.32 Emergency Systems (revised)
- 701.32 Legally Required Systems (revised)
- 708.54 Critical Operations Power Systems (revised)

Installations where selective coordination is mandatory in the NEC must provide selectively coordinated overcurrent protective devices adhering to the definition. This means the selective coordination analysis must be for the full range of overcurrents from overloads to the available fault current.

Selective coordination does not ever include a time specification for which above or below a given time, the overcurrent protective device characteristics are ignored. Terms such as “selective coordination greater than 0.01 seconds” or “selective coordination greater than 0.1 seconds” are incorrect terms and are not to be used when selective coordination is the objective.

In practice, when selective coordination is an objective, focus on the available fault current and whether only the nearest upstream overcurrent protective device opens and removes power only to the load(s) that must be removed. This requires analysis by a qualified person having the expertise in overcurrent protective device characteristics and how to analyze and interpret their performance when in series during overcurrent conditions.

The 2014 NEC revised definition of selective coordination reduced the misunderstandings and misleading statements about what constitutes a selectively coordinated system. The core selective coordination requirements have not changed since entering the 2005 NEC. An example is the first sentence of 700.32:

*“Emergency system(s) overcurrent devices shall be selectively coordinated with all supply-side overcurrent protective devices.”*

This core selective coordination requirement, along with the selective coordination definition, are very clear and unambiguous.

Although the core selective coordination requirement has not changed since NEC 2005, there have been some NEC sections pertaining to selective coordination with augmenting requirements and informational notes.

# Introduction

## NEC selective coordination requirements (cont.)

These augmenting requirements, which help compliance in the design and construction process as well as retaining compliance during the system life cycle, include:

- “Selective coordination shall be selected by a licensed professional engineer or other qualified persons engaged primarily in the design, installation, or maintenance of electrical systems.”
- “The selection shall be documented and made available to those authorized to design, install, inspect, maintain, and operate the system.
- Equipment enclosures containing selectively coordinated overcurrent devices shall be legibly marked: “CAUTION: OVERCURRENT DEVICES IN THIS ENCLOSURE ARE SELECTIVELY COORDINATED. EQUIVALENT REPLACEMENTS AND TRIP SETTINGS ARE REQUIRED.” (new 620.62).
- Informational notes and figures provide an example of how overcurrent protective devices selectively coordinate with all supply-side overcurrent protective devices clarifies the normal source path to emergency systems, legally required standby systems, and critical operation power systems. (new for 700.32, 701.32, and 708.54).

## Achieving selective coordination

The proper selection and function of overcurrent protective devices (OCPDs) is more than merely determining an OCPD ampere rating and voltage rating for a circuit. Selective coordination of the OCPDs in a circuit path from the service point to a load or all the circuit paths in an entire system may be a discretionary design decision (not required by the NEC) or it may be a mandatory NEC requirement for some systems or applications. When all the OCPDs in the circuit paths from the power source to the loads are selectively coordinated, the reliability of the electrical distribution system to deliver power to the loads is increased.

Typically, it is important to deal with selective coordination in the design phase. After the electrical equipment is installed, there usually is little that can be done to adjust a system that is not selectively coordinated.

Selective coordination is achieved when OCPDs are chosen such that whenever an overcurrent occurs, only the nearest lineside OCPD to the overcurrent condition opens to interrupt the overcurrent. Loads are not unnecessarily interrupted. See Figure 1.

## Achieving selective coordination (cont.)

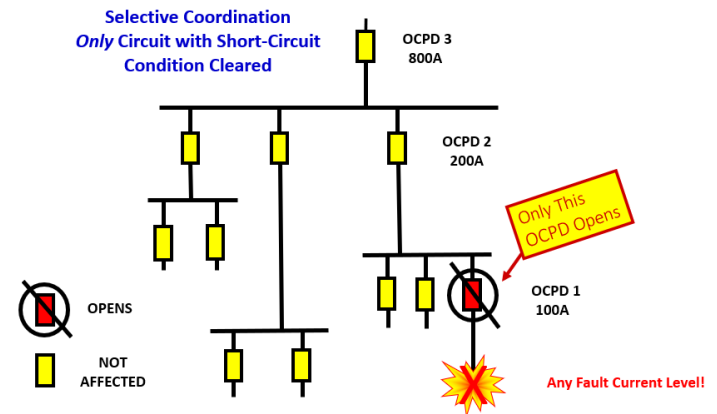

**Figure 1.** In this example, selective coordination means if a fault occurs on the load side of OCPD 1 (100 A), only that OCPD opens. Neither OCPD 2 (200 A) nor OCPD 3 (800 A) opens. Selective coordination also means this principle is valid for the full range of overcurrents including the available fault currents throughout the system being analyzed.

If OCPDs are not selectively coordinated on a circuit path (main, feeder, and branch circuit), multiple levels of overcurrent protective devices in series can open. As a result, unnecessary opening of the upstream overcurrent protective devices causes some loads to be unnecessarily interrupted. The most problematic overcurrent condition for achieving selective coordination typically is for short-circuit conditions. See Figure 2.

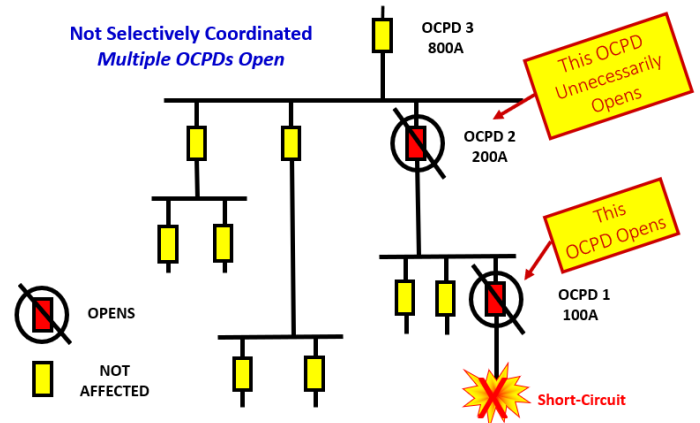

**Figure 2.** Example of non-selective coordination: for some range of fault currents, a fault as shown causes OCPD 1 to clear the circuit as intended. However, due to a lack of selective coordination, OCPD 2 unnecessarily opens, which results in some loads unnecessarily being interrupted. OCPD 3 might also unnecessarily open due to lack of selective coordination and this would result in the entire system being without power.

Merely having a larger ampere rated OCPD feeding a lower ampere rated OCPD does not ensure that a circuit is selectively coordinated. This is an important concept to understand. Achieving selective coordination requires a person qualified in choosing the proper OCPDs for the application. The degree of effort and expertise required to achieve selective coordination for a system depends on the overcurrent protective device technology used.

The simplest method to achieve selective coordination is to use the published fuse selective coordination amp rating ratios based on specific fuse types.

# Introduction

## Fuse selectivity amp rating ratios

Simply adhering to fuse selectivity amp rating ratios makes it easy to design and install fusible systems that are selectively coordinated. For modern current-limiting, low-voltage fuses, selectivity ratios are published. Figure 3 illustrates a Fuse Selectivity Ratio Guide for Bussmann™ Series fuses. It is not necessary to plot time-current curves or do an available fault current analysis; all that is necessary is to make sure the fuse types and ampere rating ratios for the mains, feeders, and branch circuits meet or exceed the selectivity ratios.

If the ratios are not satisfied, then the designer should investigate another fuse type or design change. These selectivity ratios are for all levels of overcurrent up to the fuse interrupting rating or 200,000 A (whichever is lower) of the respective fuses. The ratios are valid even for fuse opening times less than 0.01 seconds. All that is needed is to select the proper fuse type and ampere ratings. There are no curves to plot or settings to adjust. In most cases, performing available fault current calculations is not needed since most installations have available fault currents less than 200,000 A. See Figure 3.

Circuit				Downstream / loadside fuse											
Amp rating range		Fuse type	Trade name (fuse class)	601-6000 A	601-4000 A	1-400 A	0-600 A			601-6000 A	0-600 A	0-1200 A	0-600 A	0-60 A	0-30 A
				Time-delay	Time-delay	Time-delay	Dual-element, time-delay			Fast-acting	Fast-acting	Fast-acting	Fast-acting	Time-delay	
				Low-Peak (L)	Limitron (L)	CUBEFuse (CF) <sup>2</sup>	Low-Peak (J)	Low-Peak (RK1)	Fusetron (RK5)	Limitron (L)	Limitron (RK1)	Limitron (T)	Limitron (J)	SC (G)	(CC)
			Bussmann fuse symbol	KRP-C-SP	KLU	TCF	LPJ-SP	LPN-RK-SP LPS-RK-SP	FRN-R FRS-R	KTU	KTN-R KTS-R	JJN JJS	JKS	SC	LP-CC FNO-R KTK-R
Upstream / lineside fuse	601 to 6000 A	Time-delay	Low-Peak (L)	KRP-C-SP	2:1	2.5:1	2:1	2:1	2:1	4:1	2:1	2:1	2:1	2:1	2:1
	601 to 4000 A	Time-delay	Limitron (L)	KLU	2:1	2:1	2:1	2:1	2:1	4:1	2:1	2:1	2:1	2:1	2:1
	0 to 600 A	Dual-element	Low-Peak (RK1)	LPN-RK-SP LPS-RK-SP	—	—	2:1	2:1	2:1	8:1	—	3:1	3:1	3:1	4:1
	0 to 600 A	Dual-element	Low-Peak (J)	LPJ-SP	—	—	2:1	2:1	2:1	8:1	—	3:1	3:1	3:1	4:1
	0 to 400 A	Dual-element	CUBEFuse (CF) <sup>2</sup>	TCF	—	—	2:1	2:1	2:1	8:1	—	3:1	3:1	3:1	4:1
	0 to 600 A	Dual-element	Fusetron (RK5)	FRN-R FRS-R	—	—	1.5:1	1.5:1	1.5:1	2:1	—	1.5:1	1.5:1	1.5:1	1.5:1
	601 to 6000 A	Fast-acting	Limitron (L)	KTU	2:1	2.5:1	3:1	3:1	3:1	6:1	2:1	2:1	2:1	2:1	2:1
	0 to 600 A	Fast-acting	Limitron (RK1)	KTN-R KTS-R	—	—	3:1	3:1	3:1	8:1	—	3:1	3:1	3:1	4:1
	0 to 1200 A	Fast-acting	Limitron (T)	JJN JJS	—	—	3:1	3:1	3:1	8:1	—	3:1	3:1	3:1	4:1
	0 to 600 A	Fast-acting	Limitron (J)	JKS	—	—	3:1	3:1	3:1	8:1	—	3:1	3:1	3:1	4:1
	0 to 60 A	Time-delay	SC (G)	SC	—	—	3:1	3:1	3:1	4:1	—	2:1	2:1	2:1	2:1

Figure 3. This fuse selectivity ratio table identifies the fuse amp rating ratios that ensure selective coordination.

General notes: Ratios given in this table apply to only Bussmann series fuses. When fuses are within the same case size, consult factory.

- Where applicable, ratios are valid for indicating and non-indicating versions of the same fuse. At some values of fault current, specified ratios may be lowered to permit closer fuse sizing. Consult factory.
- Time-delay Class CF TCF or TCF\_RN CUBEFuse are 1 to 400 A Class J performance; dimensions and construction are a unique, finger-safe design.
- The selectivity ratios in this table are for all overcurrent levels up to the fuse interrupting rating, or 200kA, whichever is lower.

# Introduction

## Example

**Figure 4.** Check the LPJ-100SP fuse selective coordination with the LPJ-400SP fuse. The amp ratio of these fuses in this circuit path is 400:100 which equals a 4:1 ratio. Checking the Selectivity Ratio Guide, lineside LPJ (left column) to load-side LPJ (top horizontal row), yields a minimum ratio of 2:1.

This indicates selective coordination for these two sets of fuses for any overcurrent condition up to 200,000 A. This means for any overcurrent on the loadside of the LPJ-100SP fuse, only the LPJ-100SP fuse opens. The LPJ-400SP fuse remains in operation as well as the remainder of the system. The KRP-C800SP fuse to LPJ-400SP fuse in the circuit path has a 2:1 ratio and the Selectivity Ratio Guide shows a ratio of 2:1. Therefore, these two fuses are selectively coordinated up to 200,000 A. Conclusion: the entire circuit path is selectively coordinated.

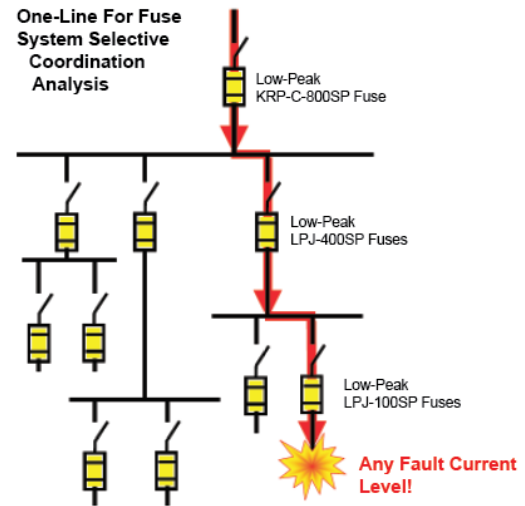

## Fuse Selectivity Amp Rating Ratios (cont.)

When using other overcurrent protective device types, different methods are needed and more in-depth selective coordination expertise is necessary. These other methods require a thorough understanding of time-current characteristics of OCPDs and the proper interpretation is essential to evaluate a circuit for selective coordination.

The performance of OCPDs operating due to medium to high-level fault currents is not always reflected on standard time-current curves. In many situations, time-current plots can be interpreted to be a lack of selective coordination when the circuit consists of multiple circuit breakers having instantaneous trips. In other cases, time-current plots may appear to be selectively coordinated but are not selectively coordinated at higher fault current levels. In most cases, other analysis methods must be utilized, and/or it requires a person qualified to interpret the curves.

To determine if a loadside fuse will selectively coordinate with a lineside circuit breaker is not a simple matter. Even if the plot of the time-current curves for a loadside fuse and a lineside circuit breaker show that the curves do not cross, selective coordination may not be possible for the available fault currents in typical systems.

The only sure way to determine whether a loadside fuse will selectively coordinate with a lineside circuit breaker is to test the devices together. Eaton publishes tables for some combinations of lineside Eaton circuit breaker and loadside Bussmann series CUBEFuse™, based on testing and analysis. See Figure 5.

### 480 Vac Eaton thermal magnetic circuit breaker “quick pick” selective coordination with CUBEFuse amp ratings\*

Eaton lineside circuit breakers					Max circuit fault current (kA)	Loadside TCF or FCF CUBEFuse (amps)**
Breaker frame	Breaker family	Min. amp rating	Max amp rating			
G Frame	GHB	100	100	14†	15, 20, 25, 30, 35, 40, 50	
E Frame	EGB	125	125	18	15, 20, 25, 30, 35, 40, 50, 60	
	EHD	100	100	14	15, 20, 25, 30, 35, 40, 50	
F Frame	FD	100	100	35	15, 20, 25, 30, 35, 40, 50	
	FD	150	150	35	15, 20, 25, 30, 35, 40, 50, 60, 70	
	FD	225	225	35	15, 20, 25, 30, 35, 40, 50, 60, 70, 80, 90, 100	
J Frame	JD	70	70	35	15, 20, 25, 30	
	JD	150	150	35	15, 20, 25, 30, 35, 40, 50, 60, 70	
K Frame	KD	200	400	35	15, 20, 25, 30, 35, 40, 50, 60, 70, 80, 90, 100	
	HKD	400	400	65	15, 20, 25, 30, 35, 40, 50, 60, 70, 80, 90, 100	

\* For circuit breakers with an adjustable instantaneous trip, selective coordination is based upon instantaneous trip set at maximum.

\*\*TCF (time-delay) and FCF (fast-acting) fuses can be used on any 600 Vac or less system. The CUBEFuse has a 200 kA or 300 kA interrupting rating at 600 Vac or less.

† 480/277 Vac

**Figure 5.** This is an example of one of the lineside Eaton circuit breakers to loadside Bussmann Series CUBEFuse selective coordination tables based on testing. More tables of other Eaton circuit breakers to loadside CUBEFuses are available.

For more indepth application material on selective coordination, see publication SPD Selecting Protective Devices available at the [Eaton.com/bussmannseries](http://Eaton.com/bussmannseries) website.

**Coordination, Selective (Selective Coordination)**

Localization of an overcurrent condition to restrict outages to the circuit or equipment affected, accomplished by the selection and installation of overcurrent protective devices and their ratings or settings for the full range of available overcurrents, from overload to the maximum available fault current, and for the full range of overcurrent protective device opening times associated with those overcurrents

**Without selective coordination**

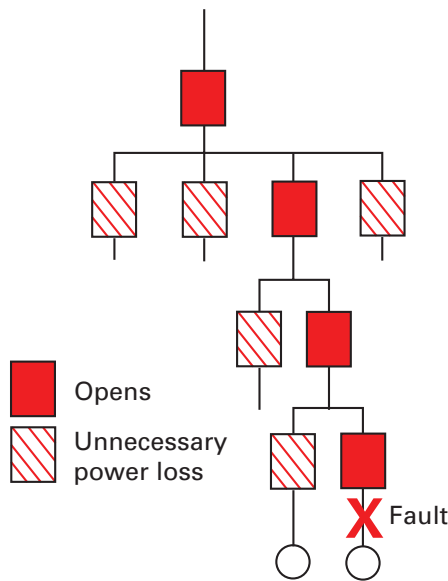

**With selective coordination**

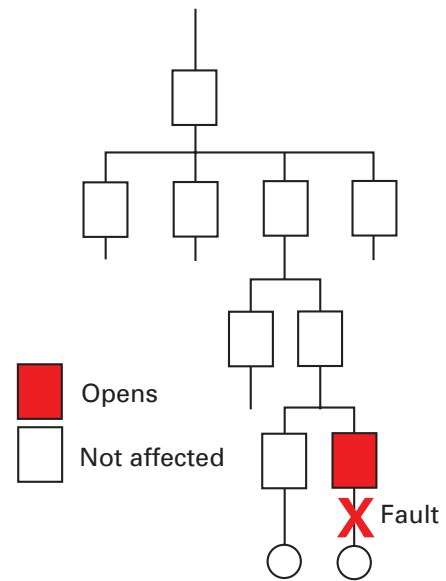

**Significance of the change**

The new definition for available fault current is “the largest amount of current capable of being delivered at a point on the system during a short-circuit condition.” Therefore, the term “maximum” is not necessary since “available fault current” is the maximum fault current that can be delivered at a given point.

This affirms that, when selecting overcurrent protective devices to provide selective coordination, the analysis should include the largest amount of current capable of being delivered, which is derived by determining the available fault current.

**Related NEC Sections**

- Article 100 Definitions, Fault Current
- Article 100 Definitions, Available Fault Current
- 620.62
- 620.65
- 645.27
- 695.3(C)(3)
- 700.10(B)(5)(b)(ii)
- 700.32
- 701.32
- 708.54

See more information in discussion on 700.32 change and selective coordination in front of this publication

**Change summary**

- Delete “maximum” since incorporated in new definition “available fault current”

**Fault Current**

The current delivered at a point on the system during a short-circuit condition.

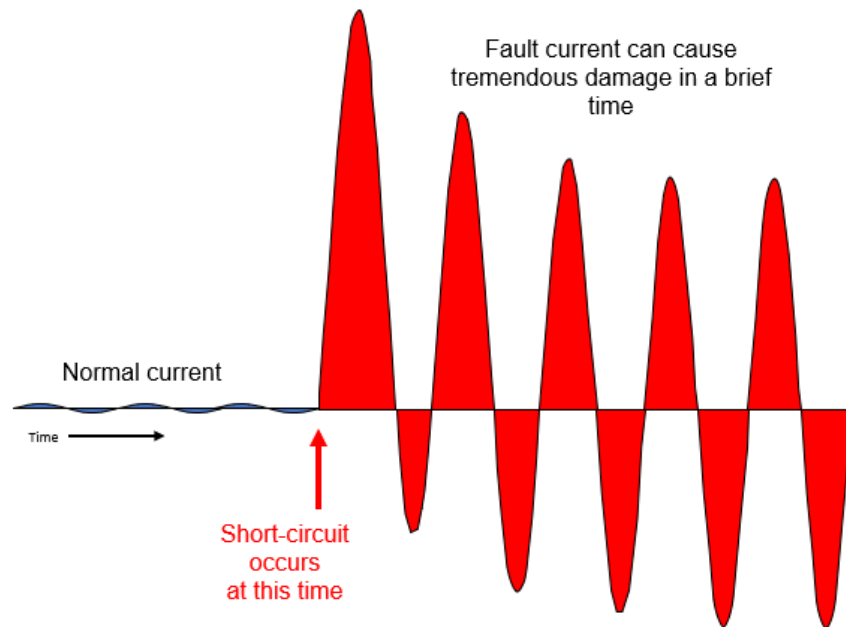

### Significance of the change

Article 100 in Part I General has a new definition “Fault Current.” This term is intended to be used consistently throughout the NEC for current resulting from a short-circuit condition. Prior to the 2020 edition, “fault current” and “short-circuit current” were used interchangeably throughout the NEC, causing a lack of consistency. Now the proper term to use for the current that flows due to a short-circuit condition on an energized circuit is “fault current” and not “short-circuit current.”

Fault current is one type of “overcurrent,” which is also defined in Article 100. During a short-circuit condition, the load is shorted out of the circuit and the fault current leaves the normal circuit conduction path. “Overload” current is another type of overcurrent that results from an overload condition. During an overload condition, the current stays within the normal conduction path. Overload is defined in Article 100, too.

A companion change is the new definition ‘available fault current’ and Informational Note Figure 100.1

Presently, the electrical industry uses “fault current” and “short-circuit current” interchangeably in verbal and written communications. The industry should evolve to consistently using the term “fault current” when a short-circuit condition occurs.

### Related NEC Sections

- Overcurrent definition
- Available fault current definition
- Overload definition
- Numerous NEC requirements

### Change summary

- “Fault Current” is a new definition
- Term to be consistently used for current resulting from a short-circuit condition

**Fault Current, Available  
(Available Fault Current)**

The largest amount of current capable of being delivered at a point on the system during a short-circuit condition. Informational Note: A short-circuit can occur during abnormal conditions such as a fault between circuit conductors or a ground fault. See Informational Note Figure 100.1. (Figure 100.1 is shown to the right)

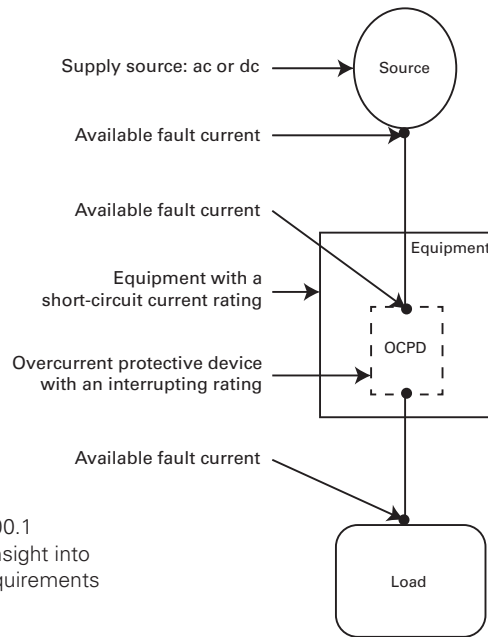

New Informational Note Figure 100.1  
Available Fault Current provides insight into proper terminology for several requirements in the NEC.

## Significance of the change

This new definition establishes the term “available fault current,” which is used in many NEC requirements. The intent is it replaces “available short-circuit current,” “maximum available fault current,” and other similar terms that were used but not defined in the NEC.

The calculation of available fault current at any point in the system must be for the worst-case (greatest) fault current that could occur at that point in the electrical system. “Largest amount of current” in the definition means available fault current is a short-circuit condition with negligible impedance in which the industry assumes zero impedance for calculation purposes. And values for other variables affecting the available fault current calculation must be selected to result in the largest amount of fault current. In essence, this definition then embodies the maximum current possible in the term available fault current.

There are many requirements in the NEC in which the available fault current must be determined, such as, to ensure circuit breakers and fuses have sufficient interrupting ratings (110.9), devices and assemblies have sufficient short-circuit current ratings (110.10 plus many more sections), overcurrent protective devices provide selective coordination (700.32 and numerous other sections) for the full range of overcurrents.

Information Note Figure 100.1 (shown above) illustrates the use of the terms available fault current, short-circuit current rating, and interrupting rating, all of which are now defined in the NEC.

### Related NEC Sections

- Fault current definition
- Overcurrent definition
- 110.9
- 110.10
- Numerous NEC requirements

## Change summary

- “Available fault current” is a new definition to assist achieving consistency throughout the NEC
- Replaces available short-circuit current, maximum available short-circuit current, maximum short-circuit current available, and maximum available fault current which were used throughout the NEC
- This is the maximum zero impedance fault current resulting from a short-circuit condition

Fault current analysis determines the available fault current for one or more points in a system, typically necessary for proper design, equipment procurement, system installation, and system life cycle.

The available fault current may be needed at every point in the system where there is an overcurrent protective device (OCPD) or electrical equipment such as a switchboard, panelboard, industrial control panel or HVAC equipment. The available fault current is necessary for many reasons including:

- NEC requirements to field mark and/or document the available fault current at the point of installation for specific equipment, such as 110.24 and the new 408.6
- Sufficient circuit breaker and fuse interrupting ratings (110.9)
- Sufficient equipment short-circuit current ratings (110.10 & other sections)
- Input for overcurrent protective device selective coordination analysis (700.32 & other sections)
- Necessary data needed to determine the necessary arc rated PPE per NFPA 70E (130.5)

Modifications or expansion of an electrical distribution system can change the available fault current. A common occurrence is the utility changing the service transformer due to transformer failure or need to increase kVA capacity. If the transformer has a larger kVA rating and/or lower percentage impedance, the available fault currents in a premise can increase significantly. Calculating the available fault current is relatively straight forward and can be performed by using well-established equations and industry data, commercial power analysis software applications, or free apps. See the resources on this page.

## More resources

### Calculating available fault current

- FC<sup>2</sup> Available Fault Current Calculator (no cost): downloadable from app store or run on-line [www.cooperbusmann.com/FC2](http://www.cooperbusmann.com/FC2)
- Point-to-point fault current calculation method in Selecting Protective Devices handbook [www.cooperbusmann.com/spd](http://www.cooperbusmann.com/spd) provides the equations and necessary data to calculate available fault current using calculator

### Applying available fault current

- Selecting Protective Devices handbook [www.cooperbusmann.com/spd](http://www.cooperbusmann.com/spd) sections on:
- Interrupting rating, including links to videos of test demonstrations
  - Bussmann series fuse interrupting ratings
  - Series ratings and tables of fuses protecting circuit breakers in series rating combinations
  - NEC 110.24 marking service entrance equipment with available fault current
  - Short-circuit current rating: what it means, how to comply
  - Industrial control panels: Determining SCCR of industrial control panels per UL 508A Supplement SB
  - Electrical safety and arc flash risk assessment

## Solution or products

Designed for three-phase and single-phase systems. A quick, easy method to calculate available fault current at one or multiple points in an electrical distribution system. App available to download for both Apple and Android mobile devices. Web-based version via [www.cooperbusmann.com/FC2](http://www.cooperbusmann.com/FC2). [Product profile No. 10106](#).

FC<sup>2</sup> available fault current calculator

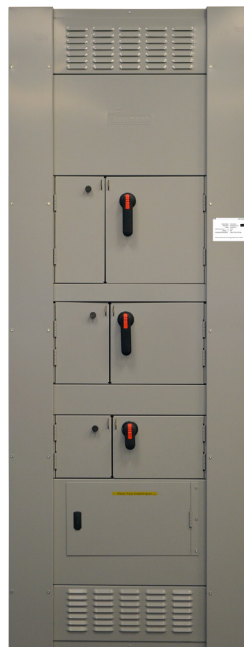

**EATON BUSSMANN SERIES** FC<sup>2</sup> available fault current calculator

Project Name: **Corner Mall - Unit 1**  
 Fault Name: **X2**  
 System: **Three-Phase**  
 Avail. Fault Current L-L-L (Amps): **52,509**  
 Voltage L-L (Volts): **480**  
 Calculation Performed On: **Sep 1, 2016 @ 4:53pm**

Calculation performed via Eaton's Bussmann Series Available Fault Current Calculator v1.5

**EATON BUSSMANN SERIES** FC<sup>2</sup> available fault current calculator

**Your System Details**

Project Name: Corner Mall - Unit 1  
 System Type: Three-Phase  
 Creator Name: Bill Powers  
 Creator Email: [BPowers@electricalsystems.com](mailto:BPowers@electricalsystems.com)  
 Creator Company/Organization: Electrical Systems  
 Creator Title/Position: Engineer  
 Creation Date: Sep 1, 2016 @ 5:06pm

**FAULT - X1**  
 I<sub>sc</sub> 12,000 AMPS  
 Voltage (L-L) 13,200 V

**TRANSFORMER - T1**  
 kVA 1,500  
 Voltage 480  
 %Z 2.38  
 %Z TOL -10% (Max Fault)

**FAULT - X2**  
 I<sub>sc</sub> 51,305 AMPS  
 I<sub>sc</sub> 1,204 AMPS  
 I<sub>sc</sub> 52,509 AMPS  
 Voltage (L-L) 480 V

**MOTOR CONTRIBUTION - M1**  
 MOTOR 400 V  
 MOTOR I<sub>sc</sub> 301 AMPS  
 MOTOR CONTRIBUTION 1,204 AMPS

Example of FC<sup>2</sup> Available Fault Current Calculator documentation (right) and electronic formatting of label to affix on equipment (above).



#### Reconditioned

Electromechanical systems, equipment, apparatus, or components that are restored to operating conditions. This process differs from normal servicing of equipment that remains within a facility, or replacement of listed equipment on a one-to-one basis.

**Informational Note:** The term reconditioned is frequently referred to as rebuilt, refurbished, or remanufactured.

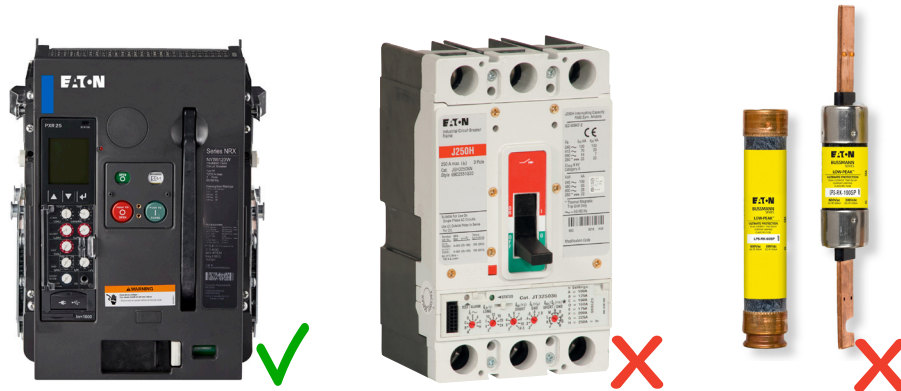

#### Related NEC Sections

- 110.21 Marking
- Equipment that provides ground-fault circuit-interrupter protection for personnel (210.15)
- Equipment that provides arc-fault circuit-interrupter protection (210.15)
- Equipment that provides ground-fault protection of equipment (210.15)
- Low-voltage fuseholders (240.62)
- Low-voltage nonrenewable fuses (240.62)
- Molded-case circuit breakers (240.88)
- Low-voltage power circuit breaker electronic trip units (240.88)
- Medium-voltage fuseholders (240.102)
- Medium-voltage nonrenewable fuses (240.102)
- Receptacles (406.3)
- Attachment plugs, cord connectors, and flanged surface devices (406.7)
- Panelboards (408.8)
- Luminaires, lampholders, and retrofit kits (410.7)
- Listed low-voltage lighting systems or a lighting system assembled from listed parts (411.4)
- Fire pump controllers and transfer switches (695.10)
- Automatic transfer switches (700.5, 701.5, 702.5, 708.24)
- Low- and medium-voltage power circuit breakers (240.88)
- High-voltage circuit breakers (240.88)
- Electromechanical protective relays and current transformers (240.88)
- Switchboards and switchgear, or sections of switchboards or switchgear (410.7)
- Switchgear, or sections of switchgear, within the scope of Article 490

Many different types of electrical equipment can be reconditioned such as low voltage power circuit breakers. Other equipment such as molded case circuit breakers and fuses cannot be reconditioned. See related NEC sections.

## Significance of the change

This definition helps the user of the NEC understand what is considered when determining if electromechanical systems, equipment, apparatus, or components are reconditioned. Breaking this definition down will help determine when an item falls under the definition.

1. The first sentence illustrates that this definition is broad in nature, impacting many different types of equipment. It calls out electromechanical systems, equipment, apparatus or components. This impacts all electrical equipment.
2. The second part of this first sentence notes that the equipment is restored to operating conditions. This tells the user of the NEC that the equipment was not in a working state and was modified to be placed into an operating state.
3. The second sentence of this definition explains that normal servicing of equipment, which would include replacements of listed components on a one-for-one basis, does not fall under the definition of being reconditioned. A good example of this would be replacing a fuse within a fusible switch. The fuse that is being replaced is no longer in working condition, so a new fuse is used. The switch itself is in working condition, so the switch is not being reconditioned and the manufacturer instructions are followed to place the right fuse in the fusible switch, yielding normal servicing of that equipment.

These items are important to understand as the NEC is enforced.

## Change summary

- New definition for reconditioned
- Identifies that replacement of parts within equipment on a one-for-one basis per manufacturer instructions is not considered reconditioned
- Identifies the action of taking a product from a non-working condition to a working condition through modifications would clearly fall under the definition of reconditioned
- General maintenance and normal servicing of equipment does not qualify as reconditioning

## 110.24 Available Fault Current

### Part I General

### Article 110 Requirements for Electrical Installations

### Chapter 1 General

REVISION

#### (A) Field Marking

Service equipment at other than dwelling units shall be legibly marked in the field with the **maximum** available fault current. The field marking(s) shall include the date the fault-current calculation was performed and be of sufficient durability to withstand the environment involved. The calculation shall be documented and made available to those authorized to design, install, inspect, maintain, or operate the system.

Informational Note No. 1: The available fault-current marking(s) addressed in 110.24 is related to required short-circuit current and interrupting ratings of equipment. *NFPA 70E-20152018, Standard for Electrical Safety in the Workplace*, provides assistance in determining the severity of potential exposure, planning safe work practices, and selecting personal protective equipment.

Informational Note No. 2: Values of available fault current for use in determining appropriate minimum short-circuit current and interrupting ratings of service equipment are available from electric utilities in published or other forms.

#### (B) Modifications

When modifications to the electrical installation occur that affect the **maximum** available fault current at the service, the **maximum** available fault current shall be verified or recalculated as necessary to ensure the service equipment ratings are sufficient for the **maximum** available fault current at the line terminals of the equipment. The required field marking(s) in 110.24(A) shall be adjusted to reflect the new level of **maximum** available fault current.

*Exception: The field marking requirements in 110.24(A) and 110.24(B) shall not be required in industrial installations where conditions of maintenance and supervision ensure that only qualified persons service the equipment.*



The Short-Circuit Rating is equal to the lowest:

- 1) short-circuit current rating of any switchboard section connected in series, and
- 2) short-circuit current rating of any installed panelboard that has a short-circuit current rating marked on it, and
- 3) The following:
  - 3a) interrupting rating of any installed circuit breaker or fused switch (excluding those located in a control circuit), or
  - 3b) interrupting rating of any combination of series-connected circuit breakers or fused switches as described within the attached Series Ratings Information Manual (Information Manual (IM) 1C96944H01), but is limited to a maximum of 65kA rms symmetrical amperes at 480 volts maximum.

<b>EATON</b> BUSSMANN SERIES	<b>FC<sup>2</sup></b>   available fault current calculator
Project Name: <b>Corner Mall - Unit 1</b>	
Fault Name: <b>X2</b>	
System: <b>Three-Phase</b>	
Avail. Fault Current L-L-L (Amps): <b>52,509</b>	
Voltage L-L (Volts): <b>480</b>	
Calculation Performed On: <b>Sep 1, 2016 @ 4:53pm</b>	
Calculation performed via Eaton's Bussmann Series Available Fault Current Calculator v1.5	

## Significance of the change

110.24 requires service equipment to be field marked by the installer with the available fault current and date of the fault current calculation. This allows the AHJ to more easily verify the service equipment has a proper short-circuit current rating and the overcurrent protective devices within the assembly have proper interrupting ratings.

"Maximum" was removed from the term "maximum available fault current" throughout 110.24. The new definition for available fault current incorporates the concept of "largest amount of current" so "maximum" is not needed. This means the calculation of fault current at the installation point of the service equipment must be for the worst-case (largest) fault current that could occur.

This available fault current is needed to verify that the service equipment has the short-circuit current rating equal or greater than the available fault current as required by 110.10 and the new 408.6. Informational Note No. 1 was changed to stress that 110.24(A) is intended to also verify that service equipment has overcurrent protective devices that have interrupting ratings equal to or greater than the available fault current required by 110.9.

The new Informational Note No. 2 provides advice that electric utilities are a source for the available fault current at the secondary of their service transformers. Many utilities publish the available fault current for different kVA/voltage transformers and post the document on their websites.

A significant, related new 408.6 requires all switchboards, switchgear, and panelboards have a short-circuit current rating equal to or greater than the available fault current and the available fault current must be field marked on the equipment.

## Change summary

- "Maximum" is deleted from "maximum available fault current"
- "Interrupting ratings" added to Informational Note No. 1
- NFPA 70E updated to latest edition in Informational Note No. 1
- New Informational Note No. 2 advice on how to obtain the available fault current at utility transformer

#### Related NEC Sections

- New available fault current definition
- 110.9 Interrupting Rating
- 110.10 Short-Circuit Current Ratings
- New 408.6 Short-Circuit Current Ratings

For service equipment, the intent of 110.24 is to ensure that

1. The overcurrent protective devices (OCPDs) have interrupting ratings equal to or greater than the available fault current
2. The equipment short-circuit current rating (SCCR) is equal to or greater than the available fault current.
3. If system changes occur that affect the available fault current, there should be a recalculation and verify the OCPD interrupting ratings and equipment SCCR ratings are still sufficient.

The OCPDs selected provide the ability to comply with 110.9 for proper OCPD interrupting ratings and for the service equipment to comply with 110.10 and 408.6 for proper equipment SCCR. Service equipment utilizing modern current-limiting fuses usually meet the 110.9, 110.10 and 408.6 requirements because most of these type fuses have 200,000 A or 300,000 A interrupting ratings and make it easy for the equipment assembly to achieve 200,000 A SCCR. See Solution section to the right.

The Bussmann series FC<sup>2</sup> Fault Current Calculator, is a free app for Apple and Android mobile devices. With this app, it is easy to calculate the available fault current, document the calculation, get an electronic formatted label, and print/affix the label to the assembly. For safety, when changes to the system occur that may increase the available fault current at the service equipment, adherence to 110.24(B) is necessary. Verify that the available fault current marked on the service equipment is still valid; if not, a new label marked with the new value of available fault current and date of calculation is required. If the new available fault current exceeds the equipment SCCR or OCPD interrupting ratings, the equipment is a safety hazard that must be addressed.

A common occurrence is the utility changing the service transformer due to transformer failure or need to increase the kVA. If the transformer has a larger kVA rating and/or lower percentage impedance, the available fault currents can greatly increase.

## More resources

### Calculating available fault current

- FC<sup>2</sup> Available Fault Current Calculator (no cost): downloadable from app store or run on-line [www.cooperbussmann.com/FC2](http://www.cooperbussmann.com/FC2)
- Point-to-point fault current calculation method in Selecting Protective Devices handbook [www.cooperbussmann.com/spd](http://www.cooperbussmann.com/spd) provides the equations and necessary data to calculate available fault current using calculator

### Applying available fault current

Selecting Protective Devices handbook [www.cooperbussmann.com/spd](http://www.cooperbussmann.com/spd) sections on:

- Interrupting rating, including links to videos of test demonstrations
- Bussmann series fuse interrupting ratings
- Series ratings and tables of fuses protecting circuit breakers in series rating combinations
- NEC 110.24 marking service entrance equipment with available fault current
- Short-circuit current rating: what it means, how to comply
- Industrial control panels: Determining SCCR of industrial control panels per UL 508A Supplement SB
- Electrical safety and arc flash risk assessment

## Solution or products

Modern current-limiting fuses provide high interrupting ratings and a range of current-limitations that can benefit service equipment and other electrical equipment assemblies achieve high short-circuit current ratings.

(See page 60 for product options)

Tier of Protection	Line	UL Fuse Class	Symbol	AC volt rating	Amp rating	Interrupting rating (AC)
Ultimate protection	Low-Peak™	CF	TCF,TCF-RN	600	1 to 400	200,000/300,000
		J	LPJ_SP, LPJ_SPI	600	1 to 600	300,000
		RK1	LPS-RK_SP, LPN-RK_SP	600 250	1/10 to 600	300,000
		CC	LP-CC	600	1/2 to 30	200,000
		L	KRP-C_SP	600	601 to 6000	300,000
Advanced protection	Fusetron™	RK5	FRS-R FRN-R	600 250	1/10 to 600	200,000
	CUBEFuse	CF	FCF	600	1 to 100	300,000
	Limitron™	J	JKS	600	1 to 600	200,000
		RK1	KTS-R KTN-R	600 250	1 to 600	200,000
		T	JJS JJN	600 300	1 to 800 1 to 1200	200,000
	CC	KTK-R	600	1/10 to 30	200,000	
	CC	FNQ-R	600	1/4 to 30	200,000	
Basic protection	One-time	L	KTU and KLU	600	601 to 6000	200,000
		G	SC	600 480	1/2 to 20 25 to 60	100,000
		K5	NOS NON	600 250	1 to 60 1/8 to 60	50,000
		H	NOS	600	70 to 600	10,000
			NON	250	70 to 600	

The ultimate protection Low-Peak fuses are recommended since they provide the highest interrupting ratings and best current-limitation, which provide superior protection for equipment and circuits. The one-time Class H and K5 fuses have limited interrupting rating and are not marked current-limiting.

## 230.46 Spliced and Tapped Conductors

### Part IV Service Entrance Conductors

#### Article 230 Services

#### Chapter 2 Wiring and Protection

REVISION

### 230.46 Spliced and Tapped Conductors

Service-entrance conductors shall be permitted to be spliced or tapped in accordance with 110.14, 300.5(E), 300.13, and 300.15. Power distribution blocks, pressure connectors, and devices for splices and taps shall be listed. Power distribution blocks installed on service conductors shall be marked "suitable for use on the line side of the service equipment" or equivalent. Effective January 1, 2023 pressure connectors and devices for splices and taps installed on service conductors shall be marked "suitable for use on the line side of the service equipment" or equivalent.

~~230.11 Splices and Taps: Splices and taps shall be permitted. Power distribution blocks, pressure connectors, and devices for splices and taps shall be listed. Power distribution blocks, pressure connectors, and devices for splices and taps, installed on service conductors, shall be marked "suitable for use on the line side of the service equipment" or equivalent.~~

314.28(E)(1) Installation. Power distribution blocks installed in boxes shall be listed. ~~Power distribution blocks installed on the line side of the service equipment shall be listed and marked "suitable for use on the line side of service equipment" or equivalent.~~

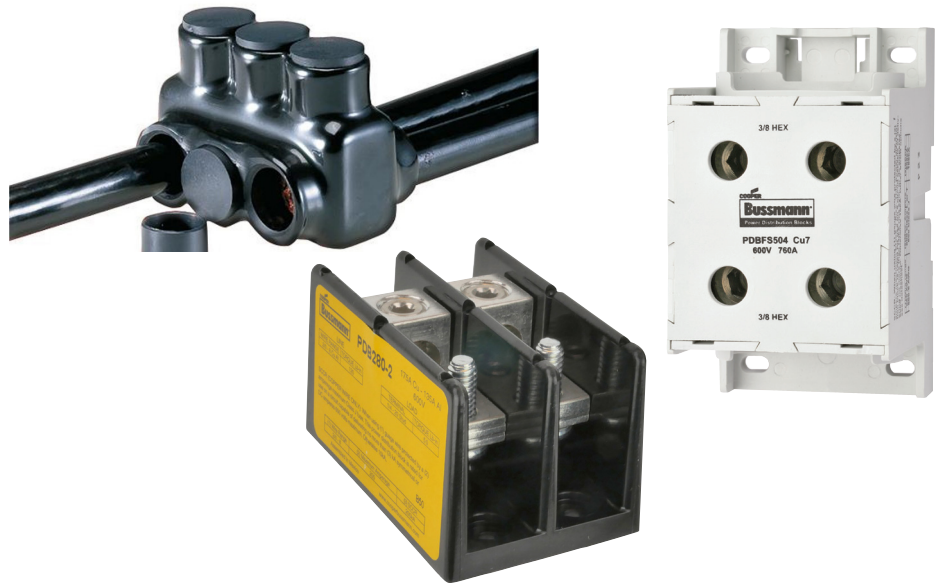

### Significance of the change

The requirement that power distribution blocks, pressure connectors, etc. for splices and taps on service conductors must be Listed did not change but was relocated from 230.11 to 230.46. Also, the requirement that power distribution blocks used for this purpose must be marked "suitable for use on the line side of the service equipment" has not changed but has been relocated from 230.11 and 314.28(E)(1) to 230.46. Effective in 2023, this revision requires pressure connectors and devices for splices and taps on service conductors must be marked "suitable for use on the line side of the service equipment." The implementation date delay provides time to develop and implement product standard testing and evaluation criteria.

This requirement is necessary because under short-circuit conditions, resulting in magnetic forces and thermal energy may cause excessive damage and safety issues. This requirement is applicable to all connectors fixed or "free-floating."

Especially problematic are smaller gauge conductors spliced or tapped from larger service conductors.

One suggestion that can provide enhanced safety is to install cable limiters on the service conductors, which can provide short-circuit protection. 230.82(1) permits installing cable limiters on the supply side of service disconnect and 240.40 permits cable limiters to be installed without disconnecting means on the supply side of service disconnecting means.

### Change summary

- 2017 NEC 230.11 requirements moved and revised to 2020 NEC 230.46
- Effective 2023, pressure connectors and devices for splices and taps on service conductors must be marked "suitable for use on the line side of the service equipment"

### Related NEC Sections

- 230.82(1)
- 376.56(B)(1)

## 230.62(C) Barriers

### 230.62 Service Equipment - Enclosed or Guarded

#### Part V Service Equipment - General

#### Article 230 Services

#### Chapter 2 Wiring and Protection

REVISION

#### **230.62(C) Barriers**

Barriers shall be placed in service equipment such that no uninsulated, ungrounded service busbar or service terminal is exposed to inadvertent contact by persons or maintenance equipment while servicing load terminations.

#### **Article 408 Switchboards, Switchgear, and Panelboards 408.3(A)**

~~(2) Service Panelboards, Switchboards, and Switchgear:~~

~~Barriers shall be placed in all service panelboards, switchboards, and switchgear such that no uninsulated, ungrounded service busbar or service terminal is exposed to inadvertent contact by persons or maintenance equipment while servicing load terminations.~~

~~*Exception: This requirement shall not apply to service panelboards with provisions for more than one service disconnect within a single enclosure as permitted in 408.36, Exceptions 1, 2, and 3.*~~



Lineside barrier provides protection from incidental contact.

## Significance of the change

This change improves safety when people work on load terminals of service equipment. Barriers must be in service equipment to avoid inadvertent contact with service bus or service terminals by persons working on the load terminations in the service equipment.

Prior to the 2017 NEC, switchboards and switchgear had to adhere to a barrier requirement in 408.3(A)(2).

For the 2017 NEC, 408.3(A)(2) added the barrier requirement for panelboards.

Now, for the 2020 NEC, the 408.3(A) requirement is relocated and revised to 230.63(C).

In addition, 230.62(C) expands this barrier requirement to any service equipment such as panelboards, switchboards, switchgear, motor control centers, transfer switches, safety switches, industrial control panels.

#### Related NEC Sections

- 2017 NEC 408.3(A)(2) deleted
- 230.71

## Change summary

- New 230.63(C) expands the 2017 NEC 408.3(A)(2) barrier requirement to all types of service equipment
- 408.3(A) deleted since new 230.63(C) encompasses the 408.3(A) barrier requirements
- 230.63(C) did not carry forward the 408.3(A) Exception since the 2020 changes to 230.71 "six disconnect rules" make it non-applicable

## 230.71(B) Two to Six Service Disconnecting Means

### 230.71 Maximum Number of Disconnects

#### Part VI Service Equipment - Disconnecting Means

#### Article 230 Services

#### Chapter 2 Wiring and Protection

REVISION

#### 230.71 Maximum Number of Disconnects

Each service shall have only one disconnecting means unless the requirements of 230.71(B) are met.

(A) General. (see 2020 NFPA 70 for text and changes to (A))

(B) Two to Six Service Disconnecting Means.

Two to six service disconnects shall be permitted for each service permitted by 230.2 or for each set of service-entrance conductors permitted by 230.40, Exception No. 1, 3, 4, or 5. The two to six service disconnecting means shall be permitted to consist of a combination of any of the following:

- (1) Separate enclosures with a main service disconnecting means in each enclosure
- (2) Panelboards with a main service disconnecting means in each panelboard enclosure
- (3) Switchboard(s) where there is only one service disconnect in each separate vertical section where there are barriers separating each vertical section
- (4) Service disconnects in switchgear or metering centers where each disconnect is located in a separate compartment

Informational Note No. 1: See 408.36, Exception No. 1 and Exception No. 3, for service equipment in certain panelboards, and see 430.95 for service equipment in motor control centers. Metering centers are addressed in UL 67, *Standard for Panelboards*. Informational Note No. 2: Examples of separate enclosures with a main service disconnecting means in each enclosure include but are not limited to motor control centers, fused disconnects, circuit breaker enclosures, and transfer switches that are suitable for use as service equipment

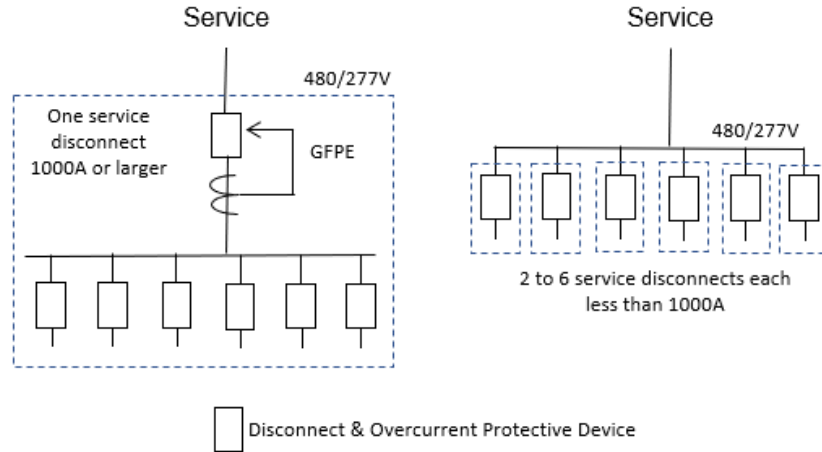

## Significance of the change

This revised requirement, in conjunction with the revised 230.62(C) service equipment barrier requirement, provides safer conditions for installation and maintenance personnel who must work in service equipment. For service equipment, except for the lineside of the service disconnection means, which now is required to have barriers per 230.62(C), a single disconnect deenergizes the conductors and other circuit parts in an enclosure, vertical section, or compartment. The result is the probability a maintenance or service worker having an incident with energized parts in service equipment is reduced.

This revision is a significant modification to the prior NEC 230.71 “six disconnect rule” for service equipment. Two to six service disconnecting means are still permitted, however, the service equipment type and configuration must be one of four options in 230.71(B)(1) to (4). If two to six service disconnecting means are utilized, each service disconnecting means must be in a separate enclosure, separate switchboard barriered vertical section, or separate compartment of switchgear or metering centers. Informational Note No. 2 provides clarity that this requirement is applicable to any type of electrical equipment beyond just panelboards, switchboards, or switchgear.

The flexibility to be able to use two to six service disconnects provides the ability to avoid the cost of one large ampere rated service disconnecting means. In addition, it provides a means for higher reliability power system design: see the solutions section on next page and the introduction section Two to Six Service Disconnects and Service Terminal Barriers and 701.31 change discussion in this publication.

## Related NEC Sections

- 230.62(C)
- 230.40, Exception No. 1, 3, 4, or 5
- 2017 NEC 408.36 Exception 1 deleted

## Change summary

- 230.71 requires one service disconnect unless there is compliance with 230.71(B)
- Two to six service disconnects permitted, if adhere to specifics of 230.71(B)

## 230.71(B) Two to Six Service Disconnecting Means

### 230.71 Maximum Number of Disconnects

#### Part VI Service Equipment - Disconnecting Means

#### Article 230 Services

#### Chapter 2 Wiring and Protection

REVISION

Two to six service disconnecting means is still a design option if the installation complies with 230.71(B).

- Two to six service disconnects may avoid the cost of one large ampere rated service disconnect.
- Two to six lower ampere rated service disconnects may help reduce arc flash incident energy verses one large ampere rated service disconnect. Using multiple, lower ampere rated service disconnects may also avoid requirements for arc energy reduction technologies required for fuses and circuit breakers rated 1200A or higher in articles 240.67 and 240.87.
- Two to six service disconnects may avoid using ground fault protection of equipment (GFPE) as required per 230.95.
- Two to six service disconnects may avoid using ground fault protection of equipment (GFPE) on the normal supply path for emergency systems, legally required standby systems, or other portions of the system. 700.31 and 701.31 allow not using GFPE, if otherwise required in the NEC, for the alternate source of emergency systems and legally required standby systems, respectively. For larger normal systems, the two to six service disconnect rule may be used for normal source supply to emergency systems and legally required standby systems, if the service disconnect can be kept less than 1000A. See Figure 6, 7 and 8.

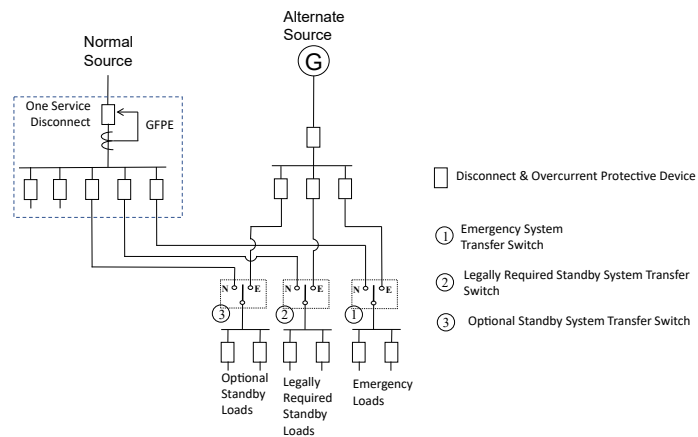

**Figure 6** Normal source service at 480/277 V and service disconnect 1000 A or greater having GFPE per 230.95.

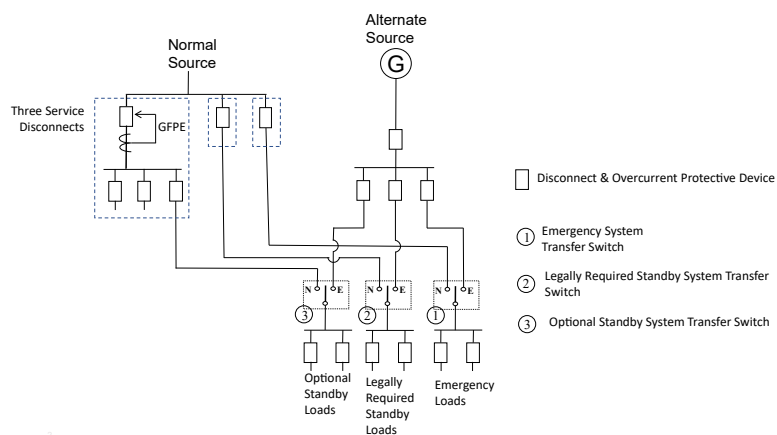

**Figure 7** If the normal source disconnects to the emergency system and legally required standby system are less than 1000 A, the 230.71(B) two to six service disconnect rule permits this configuration with GFPE. (480/277 V system)

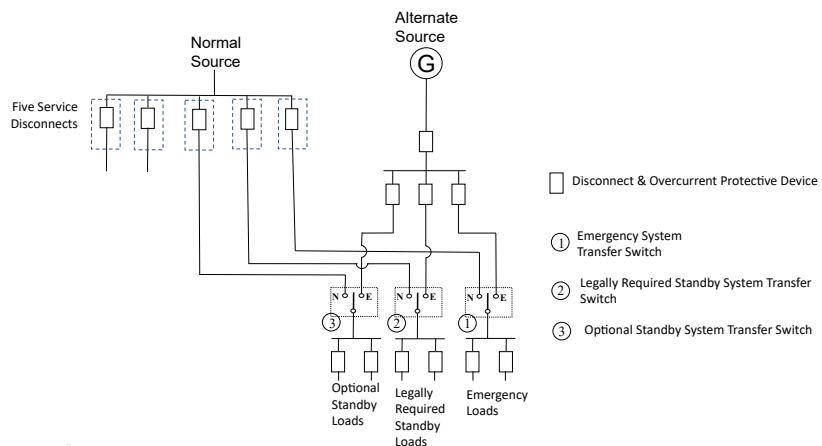

**Figure 8** If the normal source disconnects to the emergency system and legally required standby system are less than 1000 A, as well as the other normal source disconnects, the 230.71(B) two to six service disconnect rule permits this configuration without GFPE. (480/277 V system)

**230.85 Emergency Disconnect(s)**  
**Part VI Service Equipment - Disconnecting Means**  
**Article 230 Services**  
**Chapter 2 Wiring and Protection**

**NEW**

**230.85 Emergency Disconnects**

For one- and two-family dwelling units, all service conductors shall terminate in disconnecting means having a short-circuit current rating equal to or greater than the available fault current, installed in a readily accessible outdoor location. If more than one disconnect is provided, they shall be grouped. Each disconnect shall be one of the following:

(1) Service disconnects marked as follows:

EMERGENCY DISCONNECT, SERVICE DISCONNECT

(2) Meter disconnects installed per 230.82(3) and marked as follows:

EMERGENCY DISCONNECT, METER DISCONNECT, NOT SERVICE EQUIPMENT

(3) Other listed disconnect switches or circuit breakers on the supply side of each service disconnect that are suitable for use as service equipment and marked as follows:

EMERGENCY DISCONNECT, NOT SERVICE EQUIPMENT

Markings shall comply with 110.21(B).



## Significance of the change

This is an important new requirement to help ensure better safety for first responders. One and two family dwellings required to have a readily accessible outdoor emergency disconnect for first responders. Intent is to have an outdoor disconnect that can safely remove power from the structure. Disconnects must be grouped, if there are more than one.

There are three options for this emergency disconnect with specific markings for each required:

1. A service disconnect: Serves as outdoor emergency disconnect and the electrical system service disconnect
2. Meter disconnect: Serves as outdoor emergency disconnect and meter disconnect
3. Other disconnect switches and circuit breakers: Serves as outdoor emergency disconnect

230.82(10) permits option 3 to be installed on the supply side of the service disconnect. 230.82(3) permits option 2 to be installed on the supply side of the service disconnect.

Each of these disconnect options is required to have a short-circuit current rating equal or greater than the available fault current. This is an important requirement since the available fault current is the greatest at the location of these disconnects. Fusible switches utilizing current-limiting fuses usually have short-circuit current ratings of 100 kA or 200 kA and are an easy means to comply.

## Related NEC Sections

- 230.82
- 230.62(C)

## Change summary

- Readily accessible outdoor emergency disconnect for first responders is required for one and two family dwelling units
- Multiple options available
- Must be grouped, if multiple disconnects provided
- Disconnect(s) must have short-circuit current rating equal to or greater than available fault current



**240.40 Disconnecting Means for Fuses**

Cartridge fuses in circuits of any voltage where accessible to other than qualified persons, and all fuses in circuits over 150 volts to ground, shall be provided with a disconnecting means on their supply side so that each circuit containing fuses can be independently disconnected from the source of power. A ~~current-limiting device~~ cable limiter without a disconnecting means shall be permitted on the supply side of the service disconnecting means as permitted by 230.82. A single disconnecting means shall be permitted on the supply side of more than one set of fuses as permitted by 430.112, Exception, for group operation of motors, and 424.22(C) for fixed electric space-heating equipment, and 425.22(C) for fixed resistance and electrode industrial process heating equipment, or where specifically permitted elsewhere in this Code.



The Bussmann series Compact Circuit Protector for Class CF CUBE Fuse delivers the smallest footprint compared to any Class J fused disconnect solution – requiring up to 69% less space. Also available for Class CC fuses up to 30 A.

**Significance of the change**

This change ensures safer work practices by deleting the permission not requiring a supply side disconnecting means for each set of cartridge fuses. There are several permissions elsewhere in the NEC in which a single disconnecting means can be used on the supply side of more than one set of fuses.

Cable limiters used on the supply side of the service disconnecting means are not required to have a supply side disconnecting means.

**Related NEC Sections**

- 230.82(1)
- 430.112 Exception
- 424.22(C)
- 425.22(C)

**Change summary**

- In general, each set of cartridge fuses and all fuses in circuits greater than 150 V to ground must be provided with a supply side disconnecting means
- Deleted is permission where it is not necessary if cartridge fuses are accessible only to qualified persons
- Cable limiters on the supply side of the service disconnecting means are not required to have a supply side disconnecting means
- There are permissions where a single supply side disconnecting means can be used for several sets of fuses

**240.62 Reconditioned Equipment**

Low-voltage fuseholders and low-voltage nonrenewable fuses shall not be permitted to be reconditioned.

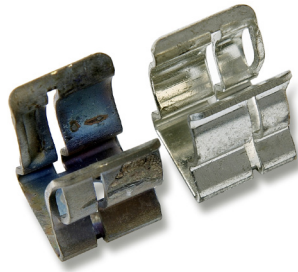

A loose conductor termination caused overheating, eventually annealing the fuseclip on the left. Per NEC 240.62, the fuseblock cannot be refurbished by replacing just the fuseclip. The entire fuseblock would need to be replaced.



**Significance of the change**

Low-voltage fuseholders and low voltage nonrenewable fuses are not permitted to be reconditioned. Reconditioned is defined in Article 100, making it clear that a fuse that has interrupted an overcurrent to protect a circuit and equipment cannot be modified and put back into working order as that would fall under the definition of being refurbished. When a fuse opens, it should be replaced with a new, factory calibrated fuse of the same, or superior, fuse type (e.g. a non-current-limiting Class H fuse can be upgraded to a current-limiting Class RK1 fuse). A fuse that has incurred physical abuse, such as submerged in flood water, is not permitted to be reconditioned. It should be noted that Class H renewable fuses that have internal elements designed to be replaced are only allowed to be used for replacement in existing installations and are not permitted for new applications per 240.60(D). It is recommended to replace renewable fuses with Class RK1 fuses, thereby providing increased safety due to current-limitation and high interrupting ratings.

**Related NEC Sections**

- 100 Definition of Reconditioned

**Change summary**

- Low-voltage fuseholders are not permitted to be reconditioned
- Low-voltage nonrenewable fuses are not permitted to be reconditioned

# 240.67 Arc Energy Reduction

## Part VI Cartridge Fuses and Fuseholders

### Article 240 Overcurrent Protection

#### Chapter 4 Equipment for General Use

REVISION

#### 240.67 Arc Energy Reduction

Where fuses rated 1200 A or higher are installed, 240.67(A) and (B) shall apply. This requirement shall become effective January 1, 2020.

##### (A) Documentation.

Documentation shall be available to those authorized to design, install, operate, or inspect the installation as to the location of the fuses.

Documentation shall also be provided to demonstrate that the method chosen to reduce clearing time is set to operate at a value below the available arcing current.

##### (B) Method to Reduce Clearing Time.

A fuse shall have a clearing time of 0.07 seconds or less at the available arcing current, or one of the following means shall be provided and shall be set to operate at less than the available arcing current:

- (1) Differential relaying
- (2) Energy-reducing maintenance switching with local status indicator
- (3) Energy-reducing active arc-flash mitigation system
- (4) Current-limiting, electronically actuated fuses

(5) An approved equivalent means  
Informational Note No. 1: An energy-reducing maintenance switch allows a worker to set a disconnect switch to reduce the clearing time while the worker is working within an arc-flash boundary as defined in NFPA 70E-20152018, *Standard for Electrical Safety in the Workplace*, and then to set the disconnect switch back to a normal setting after the potentially hazardous work is complete.

Informational Note No. 2: An energy-reducing active arc-flash mitigation system helps in reducing arcing duration in the electrical distribution system. No change in the disconnect switch or the settings of other devices is required during maintenance when a worker is working within an arc-flash boundary as defined in NFPA 70E-20152018, *Standard for Electrical Safety in the Workplace*.  
Informational Note No. 3: IEEE 1584-2002, *IEEE Guide for Performing Arc Flash Hazard Calculations*, is one of the available methods that provides guidance in determining arcing current.

##### (C) Performance Testing.

Where a method to reduce clearing time is required in 240.67(B), the arc energy reduction system shall be performance tested when first installed on site. This testing shall be conducted by a qualified person(s) in accordance with the manufacturer's instructions.

Performance testing of an instantaneous element of the protective device shall be conducted by a qualified person(s) using a test process of primary current injection and the manufacturer's recommended test procedures. A written record of this testing shall be made and shall be available to the authority having jurisdiction.



The opening time of the OCPD can have a significant impact on arc flash incident energy. The photo on the left shows a 3-phase arcing fault event with an OCPD having a 6 cycle (0.1 seconds) opening time vs the photo on the right showing the same circuit setup and equipment protected by current-limiting fuses which opened in less than ½ cycle (0.008 seconds).

## Significance of the change

Documentation must be provided to the AHJ showing that 1200 A or greater fuses clear the available arcing current in 0.07 seconds or less. If this clearing time criteria is not met, then one of the arc reduction technologies per 240.67 must augment the fuse protection. This will require first calculating the available fault current at the point of the fuse installation and then the resulting available arcing current. The available arcing current value must be compared with the fuse time-current curve to determine if the clearing time will be faster than 0.07 seconds.

In addition, the NEC now recognizes electronically actuated current-limiting fuses that respond on demand to open, should a signal be sent to it from a relay.

Performance testing is now required upon installation to show that the arc reduction technology, if required to be installed, functions. This is very similar to GFPE performance testing as required in other sections of the NEC.

## Change summary

- All fuses 1200 A and greater are now impacted
- Arcing currents must be calculated to ensure activation of the arc reduction solution provided
- Performance testing is required upon installation

#### Related NEC Sections

- 240.87 Incident energy reduction for circuit breakers

Fuses rated 1200 amps and greater are impacted by the changes of 240.67. An understanding of available fault current and the associated arcing current values is an important first step to determine if additional arc reduction mitigation equipment is required to be installed for these fuse installations. The parent text of 240.67 states that arc reduction technologies are required when the fuses in the equipment are rated 1200A and higher and do not have a clearing time of 0.07 seconds or faster at the available arcing current. As per the figure below, each fuse rated 1200 A and above will have a defined ampere value on their time-current curve beyond which higher available arcing currents will result in clearing times faster than 0.07 seconds. See **Figure 9** to the right.

**Figure 10** is a table that represents those established available arcing current values beyond which the clearing time of the fuse will be faster than 0.07 seconds.

To determine if additional arc reduction equipment is required per 240.67 for fuse installations of 1200 A or greater, use the following process:

1. Determine the available fault current at the point of installation of the fuse. The Bussmann Series FC<sup>2</sup> tool or other power system analysis software applications can be used.
2. Calculate the minimum arcing current based on the voltage, available fault current and any other information necessary for the method used, such as IEEE 1584, 2018 Edition.
3. Compare the kA values in **Figure 10** with this calculated value. If the calculated value of arcing current is greater than that which is in **Figure 10**, the requirements for arc reduction technologies are not required to be installed as the 0.07 second clearing time criteria has been satisfied.
4. If the calculated value of arcing current is less than that which is in the above table, an arc reduction technology is required to be installed on this equipment.

As an example, if we have a 600V, 1200A safety switch as service entrance equipment and the available fault current from the utility is 60,000A, the lowest calculated arcing current per IEEE 1584-2018 is 34.49kA which is much greater than the 11.02kA of arcing current shown in Figure 10 as the minimum arcing current to get a clearing time faster than 0.07 seconds. 34.49kA of arcing current is well within the current limiting region of a 1200A fuse. This installation would not require additional arc reduction means beyond the current-limiting fuses.

If the arcing current was less than 11.02kA then the 1200A fuse would have a clearing time of greater than 0.07 seconds and the following solutions would be available to meet the new requirements.

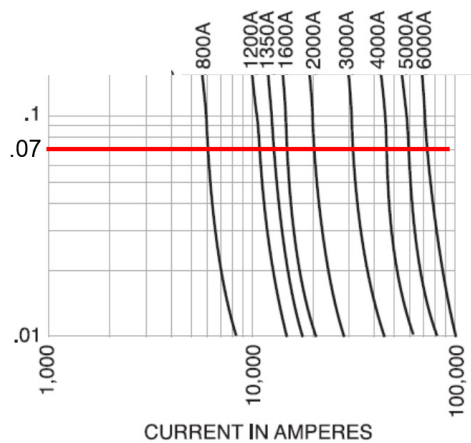

**Figure 9**

Fuse	Ampere rating (A)	Arcing current (kA)
KTU	1200	11.02
KTU	1400	13.54
KTU	1500	14.7
KTU	1600	15.7
KTU	1800	18.6
KTU	2000	21.23
KTU	2500	26.65
KTU	3000	32.58
KTU	3500	40.05
KTU	4000	51.08

**Figure 10**

## More resources

- Time-current curves for [KTU](#), [KRP-C 2001-6000](#), [KRP-C 601-2000](#) and [KLU](#)
- FC<sup>2</sup> app and arcing current calculator

## Solution or products

Eaton 1200 A safety switch equipped with arc energy reduction maintenance switch (left photo)

Fusible high pressure contact switch equipped with arc energy reduction technology (middle and right photo, courtesy of ABB/GE)



### 240.86 Series Ratings

Where a circuit breaker is used on a circuit having an available fault current higher than the marked interrupting rating by being connected on the load side of an ~~acceptable~~ approved overcurrent protective device having a higher rating, the circuit breaker shall meet the requirements specified in 240.86(A) or (B), and (C).

(A) Selected Under Engineering Supervision of Existing Installation. ...

(B) Tested Combinations. ...

(C) Motor Contribution. Series ratings shall not be used where

(1) ~~Motors~~ Motor circuits are connected ~~on~~ between the ~~load side of the~~ higher-rated overcurrent device of a series-rated combination and on the ~~line side of the~~ lower-rated ~~overcurrent device~~ circuit breaker, and

(2) The sum of ~~the these~~ motor full-load currents exceeds one percent of the interrupting rating of the lower-rated circuit breaker.

### Series rating checklist

- ✓ Listed combination
- ✓ Marked in compliance with 110.22(B)
- ✓ Meets motor contribution restriction
- ✓ Series rated combination rating greater than or equal to available fault current

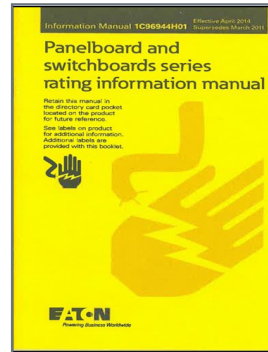

IF SERIES COMBINATION RATING ARE USED ATTACH CAUTION LABEL (BELOW) TO ANY BREAKER COVER (REF. N.E.C 110.22)

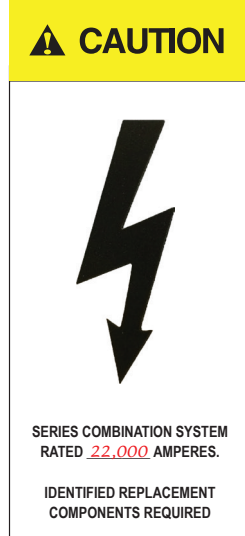

### Significance of the change

In the parent text, the word “acceptable” is changed to “approved,” which appropriately clarifies the intent of this requirement. Approved is defined in Article 100 as acceptable to the Authority Having Jurisdiction.

240.86(C) is edited for better clarity of this motor contribution requirement, which does not allow series ratings to be used under certain circumstances. This revision is prompted by a Public Input by an inspector who checks for 240.86(C) motor contribution compliance and discovers noncompliance in many installations.

If the higher rated overcurrent protective device of the series-rated combination supplies a motor circuit or multiple motor circuits, it is necessary to verify compliance to 240.86(C). The sum of the motor full-load currents that are supplied by circuits that are connected between the higher-rated circuit breaker or fuse must not exceed 1% of the lower-rated circuit breaker’s interrupting rating.

As an example, if the lower-rated circuit breaker has an interrupting rating of 10,000 amps, the sum of the full-load currents of all the motors on circuits connected between the higher-rated overcurrent protective device and the lower-rated circuit breaker cannot exceed 100 amps (1% of 10,000 amps). See the solution discussion on the next page.

### Change summary

- “Approved” replaces “acceptable,” which is more appropriate (Article 100 defines approved)
- 240.86(C) was edited for clarity

### Related NEC Sections

- 110.9
- 110.22

**240.86 Series Rating**  
**Part VII Circuit Breakers**  
**Article 240 Overcurrent Protection**  
**Chapter 4 Equipment for General Use**

**REVISION**

**Example 1**

Assessing the series combination rating for motor contribution limits in the following system. See illustration to the right.

**Step 1: Determine total motor load**

Quantity	Component	Amps
2	100 A compressors	200
2	25 hp motors @ 34 A each	68
1	10 hp pump @14 A	14
Total motor load connected between series rated devices		282

**Step 2: Does series rated combination shown comply with 240.86(C)?**

No. The series combination shown has a 100 kA series combination rating, which is sufficient or the 37 kA available fault current at PDP1. The 600 amp LPJ-600SP fuses have a 300 kA interrupting rating, which is sufficient for the 58 kA available fault current at the main switchboard. However, the series combination “protected” circuit breakers, which are located in PDP1, have a standalone or individual 22 kA interrupting rating.

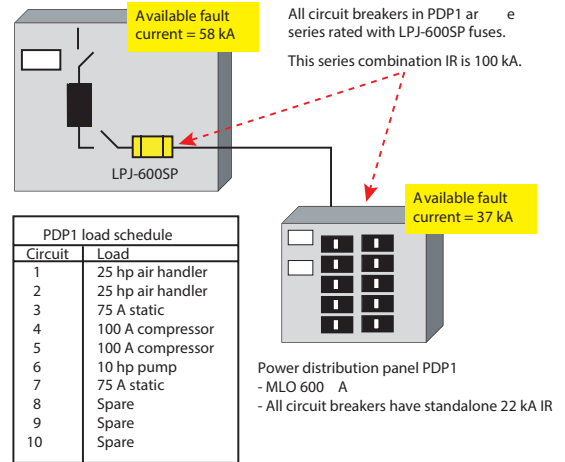

The motor load connected between the protecting and protected devices in the series rated combination cannot exceed 1% of the protected circuit breaker’s standalone interrupting rating. The motor load is 282 A, which exceeds 1% of 22 kA (220 A), making this series rated combination non-compliant with 240.86(C) for this installation.

Then consider the building’s uncertain future. Many buildings, such as office buildings, manufacturing facilities, institutional buildings and commercial spaces, by their nature, incur future changes. A properly designed and initially installed series combination rating could be compromised should building loads change to a larger percentage of motor loads.

As just illustrated, it’s not enough to just check the available fault current against the series combination rating. 240.86(C) also requires the designer, contractor and AHJ to investigate the protected circuit breaker’s individual or standalone interrupting rating in the series combination. This is necessary for series rated combinations used in new installations (tested combination) as well as existing series rated combinations, when refurbishing or upgrading existing systems.

**Example 2**

This example will use the figure to the right and the table below. This could be a panelboard with 10 kA interrupting rating circuit breakers, which are series combination rated 22 kA with the supply side circuit breaker that could be the main of the panelboard or upstream in another panel. See figure to the right.

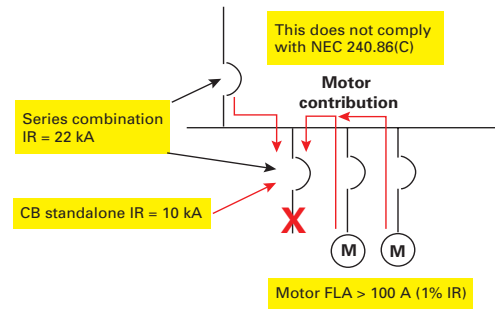

Motor full load amps must not exceed this value, if using series combination with “protected” circuit breaker having standalone interrupting rating in Column B	“Protected” circuit breaker standalone interrupting rated in series combination
(A)	(B)*
75 A	7500 AIR
100 A	10,000 AIR
140 A	14,000 AIR
180 A	18,000 AIR
200 A	20,000 AIR
220 A	22,000 AIR
250 A	25,000 AIR
300 A	30,000 AIR
350 A	35,000 AIR
420 A	42,000 AIR
500 A	50,000 AIR
650 A	65,000 AIR

Use the table to the left to evaluate the “protected” (loads) circuit breaker in a series rated combination for meeting the motor contribution limits in 240.86(C). The connected motors could contribute current where the “protected” circuit breaker (“protected” device of the “series combination”) would have to interrupt, but that the “protecting” circuit breaker (“protecting” device of the “series combination”) would not have to interrupt. In column A of the table to the left, the greater than 100 A full load motor current exceeds 100 A. Therefore, a series rating with a “protected” circuit breaker having a standalone interrupting rating of 10 kA AIR is insufficient to meet 240.86(C).

\* Some possible circuit breaker interrupting ratings per UL 489, Table 8.1.

Table for evaluating motor contribution for series ratings 240.86(C).

## 240.87 Arc Energy Reduction

### Part VII Circuit Breakers

#### Article 240 Overcurrent Protection

#### Chapter 4 Equipment for General Use

REVISION

#### 240.87 Arc Energy Reduction

Where the highest continuous current trip setting for which the actual overcurrent device installed in a circuit breaker is rated or can be adjusted is 1200 A or higher, 240.87(A) and (B) shall apply.

##### (A) Documentation.

Documentation shall be available to those authorized to design, install, operate, or inspect the installation as to the location of the circuit breaker(s). Documentation shall also be provided to demonstrate that the method chosen to reduce clearing time is set to operate at a value below the available arcing current.

##### (B) Method to Reduce Clearing Time.

One of the following means shall be provided and shall be set to operate at less than the available arcing current:

- (1) Zone-selective interlocking
  - (2) Differential relaying
  - (3) Energy-reducing maintenance switching with local status indicator
  - (4) Energy-reducing active arc flash mitigation system
  - (5) An instantaneous trip setting that is less than the available arcing current. Temporary adjustment of the instantaneous trip setting to achieve arc energy reduction shall not be permitted.
  - (6) An instantaneous override that is less than the available arcing current
  - (7) An approved equivalent means
- Informational Note No. 1: ...  
Informational Note No. 2: ...  
Informational Note No. 3: ...  
Informational Note No. 4: ...

##### (C) Performance Testing.

The arc energy reduction protection system shall be performance tested when first installed on site. This testing shall be conducted by a qualified person(s) in accordance with the manufacturer's instructions. Performance testing of an instantaneous element of the protective device shall be conducted by a qualified person(s) using a test process of primary current injection and the manufacturer's recommended test procedures. A written record of this testing shall be made and shall be available to the authority having jurisdiction.



Eaton Magnum low voltage power circuit breaker with Arc flash Reduction Maintenance System to meet the arc energy reduction requirements in 240.87.

## Significance of the change

These changes recognize that simply installing the arc reduction technology does not mean that it will perform to reduce incident energy if the arcing currents are lower than the pickup points for the technologies. This language will ensure that every installation of a circuit breaker that is rated or can be adjusted to 1200 A and above will have an arcing current in the activation area of the installed arc reduction technology. This new language also clarifies that it is NOT acceptable to “dial down” the instantaneous pickup setting in the field to meet this requirement.

Performance testing is now required upon installation to show that the arc reduction technology, if required to be installed, functions. This is very similar to GFPE performance testing as required in other sections of the NEC.

## Change summary

- All circuit breakers rated for or that can be adjusted to 1200 A and greater must have an arc reduction technology that responds to the arcing current at that point in the system
- It is NOT permitted to dial down an instantaneous setting in the field to meet this requirement
- These technologies must be performance tested upon installation

### Related NEC Sections

- 240.67 Incident energy reduction for fuse applications

**240.88 Reconditioned Equipment**

Reconditioned equipment shall be listed as “reconditioned” and the original listing mark removed.

**(A) Circuit Breakers.**

The use of reconditioned circuit breakers shall comply with (1) through (3):

(1) Molded-case circuit breakers shall not be permitted to be reconditioned.

(2) Low- and medium-voltage power circuit breakers shall be permitted to be reconditioned.

(3) High-voltage circuit breakers shall be permitted to be reconditioned.

**(B) Components.**

The use of reconditioned trip units, protective relays, and current transformers shall comply with (1) and (2):

(1) Low-voltage power circuit breaker electronic trip units shall not be permitted to be reconditioned.

(2) Electromechanical protective relays and current transformers shall be permitted to be reconditioned.

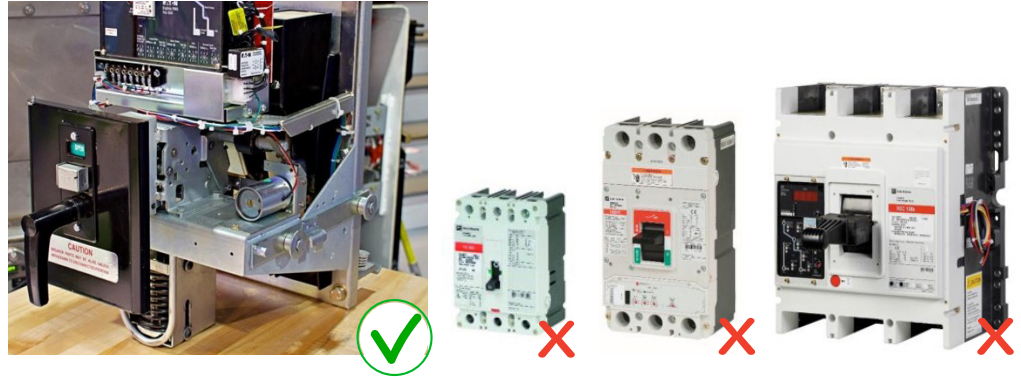

Low voltage power circuit breakers (as shown above) are allowed to be reconditioned and returned to service. Molded case circuit breakers cannot be reconditioned and must be replaced if they are no longer in operating condition.

### Significance of the change

Proposed new section 240.88 is safety-driven and is necessary to prevent the reconditioning of products that cannot be safely reconditioned. This new section advises that molded case circuit breakers (MCCBs) cannot be reconditioned, but low voltage power circuit breakers (LVPCBs), medium voltage power circuit breakers (MVPCBs) and high voltage circuit breakers can be reconditioned.

Important requirements to remember can be found in 110.21(A)(2) related to equipment markings where it is required that reconditioned products be marked with the name, trademark, or other descriptive marking by which the organization responsible for reconditioning the electrical equipment can be identified, along with the date of the reconditioning.

Reconditioned equipment shall be identified as “reconditioned” and the original listing mark removed. Approval of the reconditioned equipment shall not be based solely on the equipment’s original listing.

This section also requires that the electronic trip units for these circuit breakers are not permitted to be reconditioned.

### Change summary

- MCCBs are NOT permitted to be reconditioned
- LVPCBs are permitted to be reconditioned
- Medium voltage circuit breakers are permitted to be reconditioned
- Electronic trip units are NOT permitted to be reconditioned
- Reconditioned equipment is required to have the original listing mark removed
- Reconditioned equipment is required to be marked that it has been reconditioned and the date of said work
- Reconditioned equipment is required to be marked with the name, trademark, or other descriptive marking by which the organization responsible for reconditioning the electrical equipment can be identified

#### Related NEC Sections

- 100 Definition of reconditioned
- 110.21 Marking



**240.102 Reconditioned Equipment**  
**Part IX Overcurrent Protection over 1000 Volts, Nominal**  
**Article 240 Overcurrent Protection**  
**Chapter 4 Equipment for General Use**

**NEW**

**240.102 Reconditioned Equipment**

Medium-voltage fuseholders and medium-voltage nonrenewable fuses shall not be permitted to be reconditioned.



Medium voltage fuses cannot be reconditioned if no longer in operating condition and must be replaced with new factory calibrated replacement fuses.

### **Significance of the change**

Medium-voltage fuseholders and medium-voltage nonrenewable fuses are not permitted to be reconditioned. Reconditioned is defined in Article 100, making it clear that a nonrenewable fuse that has properly operated to interrupt an overcurrent to protect the circuit and equipment cannot be modified and put back into working order as that would fall under the definition of being refurbished. A fuse that has incurred physical abuse, such as submerged in flood water, is not permitted to be reconditioned.

#### **Related NEC Sections**

- 100 Definition of Recondition

### **Change summary**

- Medium-voltage fuseholders are not permitted to be reconditioned
- Medium-voltage nonrenewable fuses are not permitted to be reconditioned

## 408.6 Short-Circuit Current Rating

### Part I General

## Article 408 Switchboards, Switchgear, and Panelboards

### Chapter 4 Equipment for General Use

**NEW**

#### 408.6 Short-Circuit Rating

Switchboards, switchgear, and panelboards shall have a short-circuit current rating not less than the available fault current. In other than one- and two-family dwelling units, the available fault current and the date the calculation was performed shall be field marked on the enclosure at the point of supply. The marking shall comply with 110.21(B)(3).

Bussmann Quik-Spec™ Coordination Panelboard			
Panel Voltage	600 Vac	Panel Amps	200 A
System Voltage	480 / 277 Vac	Phase	3
		Wire	4Y
Short-Circuit Current Rating	200 kA	Neutral Amps	200 A
Date Code	AM4210	Enclosure Type	NEMA 1
Negotiation Number		Panel ID Number	P0001

Eaton BUSSMANN SERIES		FC <sup>2</sup> available fault current calculator	
Project Name:	Corner Mall - Unit 1		
Fault Name:	X2		
System:	Three-Phase		
Avail. Fault Current L-L (Amps):	52,509		
Voltage L-L (Volts):	480		
Calculation Performed On:	Sep 1, 2016 @ 4:53pm		

Calculation performed via Eaton's Bussmann Series Available Fault Current Calculator v1.5



### Significance of the change

This new requirement complements 110.9 for proper overcurrent protective device interrupting rating and 110.10 for equipment short-circuit current ratings and continues a trend by Code Panels to implement requirements with more prescriptive language that equipment have sufficient short-circuit current rating (SCCR) at the point of installation.

For an inspector, this requirement simplifies checking installations for compliance. Some of these assemblies are marked explicitly with a format such as "Short-Circuit Current Rating 100 kA Sym RMS at 600 V". This makes it simple for inspectors to read the available fault current marked on the equipment and verify that the equipment SCCR marked on the equipment is equal or greater than the available fault current.

Some of these assemblies, such as circuit breaker panelboards, are not marked explicitly with SCCR amperes at a rated voltage. Other factors such as the type of installed circuit breakers and their interrupting ratings must be used to derive the assembly SCCR. The interrupting rating marked on the OCPDs may not be able to be read without removing the panelboard dead front. One potential challenge for panelboards and switchboards that contain circuit breakers is that circuit breakers with lower interrupting ratings may be added later, which could reduce the panelboard and switchboard SCCR.

If the SCCR is not marked on an assembly, the AHJ may want to assume the SCCR is 5k A or 10 kA at the applied voltage. If this assumed SCCR is not equal or greater than the available fault current, then the AHJ should require the engineer and/or installer to provide documentation substantiating the assembly's actual SCCR, as installed or intended to be installed.

This safety requirement to determine the available fault current and to design and install equipment with an SCCR equal or greater than the available fault current is common sense and a necessity for safety. The contractor already needs to know the available fault current; how else would a contractor buy and install compliant equipment?

Conscientious designers and installers routinely follow the process of determining the available fault currents and then procuring and installing equipment with sufficient SCCR. Ignoring this aspect may result in procuring and installing equipment with inadequate SCCR. This can result in unfair cost competition between contractors, a building owner who ends up with an electrical installation with fire and shock hazards, and unsafe working conditions for those who maintain and service the electrical equipment.

### Change summary

- The short-circuit current rating for panelboards, switchboards, and switchgear must not be less than the available fault current
- Field mark on the enclosure the available fault current and date of calculation for installations in other than one and two-family dwelling units

#### Related NEC Sections

- 110.9
- 110.10
- Article 100 Interrupting rating definition
- Article 100 Short-circuit current rating definition
- Article 100 Fault current, available (available fault current) definition
- Numerous sections for other equipment with similar marking or documentation of available fault current requirements

## 408.6 Short-Circuit Current Rating

### Part I General

## Article 408 Switchboards, Switchgear, and Panelboards

### Chapter 4 Equipment for General Use

NEW

A short-circuit current rating is expressed in amperes at a specific voltage rating, such as 100,000A sym rms at 600 Vac or 42kA sym rms at 480 Vac. The way panelboard, switchboard, and switchgear assemblies are marked to communicate the short-circuit current rating(s) varies.

**Figure 11** illustrates a 200A fusible panelboard label which communicates the short-circuit current rating is 200,000A (sym. rms) at 600 Vac (panelboard voltage rating). The fuse mountings in this panelboard only accept current-limiting Class CF fuses which have an interrupting rating of either 200,000A or 300,000A and are rated 600 Vac. No other fuse types can be accepted by these fuse mountings. The switches associated with these fuses in this panelboard have a 200kA at 600 Vac SCCR, so the panelboard label can explicitly state 200kA SCCR.

In many cases, the SCCR for panelboards, switchboards, and switchgear is not marked explicitly on the assembly. Instead, there are markings by the assembly manufacturer that provide information which helps to determine the assembly SCCR.

**Figure 12** illustrates an 800A power distribution panelboard label. The SCCR is not explicitly expressed via a magnitude of kiloamperes. The SCCR of the panelboard varies based on the overcurrent protective devices installed in the panelboard, so they are not marked with an explicit SCCR. Instead, the label advises that the SCCR of the panelboard is determined by either:

1. If fully rated system: the SCCR is equal to the lowest interrupting rating of any OCPD in the assembly
2. If series rated OCPD system: the SCCR is equal to the lowest series rating in the assembly. Per 248.86 the series combination(s) has to be listed for the specific panelboard. UL 67, the panelboard standard, permits a series rating manual, shipped as part of the panelboard, to provide the allowed combinations of circuit breaker-to-circuit breaker series ratings and fuse-to-circuit breaker series ratings for the panelboard. See **Figure 15**. In addition, 110.22 requires the series rating expressed in amperes must be field marked on the assembly. See **Figure 14**.

Bussmann		Quik-Spec™ Coordination Panelboard	
Panel Voltage	600 Vac	Panel Amps	200 A
System Voltage	480 / 277 Vac	Phase	3
Short-Circuit Current Rating	200 kA	Wire	4Y
Date Code	AM4210	Neutral Amps	200 A
Negotiation Number		Enclosure Type	NEMA 1
		Panel ID Number	P0001

**Figure 11** Bussmann series QSCP fusible panelboard manufacturer's label with 200,000 A at 600 Vac short-circuit current rating.

Eaton		Pow-R-Line PRL-C Switchboard	
Voltage	480Y/277V	G. O. No.	SL1022088
Phase	3	Wire	4
Frequency	60 Hz	Year No.	7 001
Mfg. At.	MDS	Section No.	2
Current Ratings - Amperes		Date	11/4/2019
Supply	4000	Neut.	4000
Section	4000	Neut.	4000
Enclosure Type	1		

**IF SERIES COMBINATION RATING ARE USED ATTACH CAUTION LABEL (BELOW) TO ANY BREAKER COVER (REF. N.E.C. 110.22)**

**CAUTION**

**THE Short-Circuit Rating is equal to the lowest:**

- 1) short-circuit current rating of any switchboard section connected in series, and
- 2) short-circuit current rating of any installed panelboard that has a short-circuit current rating marked on it, and
- 3) The following:
  - a) interrupting rating of any installed switch (excluding those located in a control circuit), or
  - b) interrupting rating of any combination of series-connected circuit breakers or fused switches as described within the attached Series Ratings Information Manual (Information Manual (IM) 1C96944H01), but is limited to a maximum of 65kA rms symmetrical amperes at 480 volts maximum.

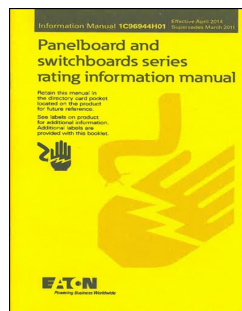

**Figure 15** Eaton series rating information manual which is affixed to Eaton panelboards and switchboards that utilize series rating OCPD.

## More resources

### Calculating available fault current

- FC<sup>2</sup> Available Fault Current Calculator (no cost): available from the app store or on-line [www.cooperbussmann.com/FC2](http://www.cooperbussmann.com/FC2)

## Solution or products

Fusible panelboards and switchboards having fuse mountings that only accept current-limiting fuses that typically have short-circuit current ratings of 200,000 A sym rms at rated voltage.

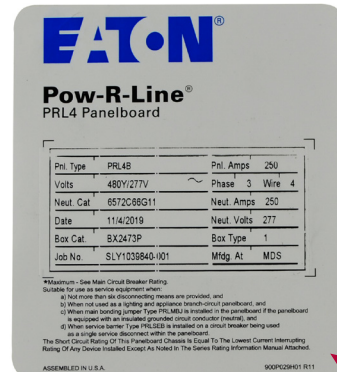

**Figure 12** Eaton PRL-4 panelboard label providing advisement on how to determine the assembly SCCR.

The Short Circuit Rating Of This Panelboard Chassis Is Equal To The Lowest Current Interrupting Rating Of Any Device Installed Except As Noted In The Series Rating Information Manual Attached.

ASSEMBLED IN U.S.A. 800P029H01 R11

**IF SERIES COMBINATION RATING ARE USED ATTACH CAUTION LABEL (BELOW) TO ANY BREAKER COVER (REF. N.E.C. 110.22)**

**CAUTION**

**SERIES COMBINATION SYSTEM RATED 22,000 AMPERES.**

**IDENTIFIED REPLACEMENT COMPONENTS REQUIRED**

**Figure 14** When series ratings are used in a panelboard or switchboard, 110.22 requires the series rating value, such as 22,000 amperes, be field marked on the assembly.



Quik-Spec Coordination Panelboard

**409.22 Short-Circuit Current Rating**  
**Part II Installation**  
**Article 409 Industrial Control Panels**  
**Chapter 4 Equipment for General Use**

**REVISION**

**409.22 Short-Circuit Current Rating**

**(A) Installation.**

An industrial control panel shall not be installed where the available short-circuit fault current exceeds its short-circuit current rating as marked in accordance with 409.110(4).

**(B) Documentation.**

If an industrial control panel is required to be marked with a short-circuit current rating in accordance with 409.110(4), the available short-circuit fault current at the industrial control panel and the date the short-circuit available fault current calculation was performed shall be documented and made available to those authorized to inspect, install, or maintain the installation.



**EATON**  
BUSSMANN  
SERIES

**FC<sup>2</sup>** available fault current calculator

Your System Details

Project Name: Commercial Plaza  
System Type: Three-Phase  
Creator Name: Arthur H Jones  
Creator Email: AHJ@wldgets.com  
Creator Company/Organization: Wldgets, Inc.  
Creator Title/Position: Supervisor  
Creation Date: Aug 2, 2016 @ 8:59am

INFINITE PRIMARY SOURCE

TRANSFORMER - T1

KVA	3,000
Voltage	480
%Z	5.00
%Z TOL	-10% (Max Fault)

FAULT - X1

$I_{sc}$	80,195 AMPS
Voltage (E-L)	480V

Manufacturer's nameplate with equipment SCCR marking required per 409.110 usually appears on the enclosure's interior. Documentation for the available fault current and the date calculation was performed is available for inspector, installer, and maintainer.

## Significance of the change

"Available fault current" replaces "available short-circuit current" and "available fault current calculation" replaces "short-circuit current calculation" to align with an effort to have consistency in terminology throughout the NEC. The term "available fault current" is a new definition added to Article 100.

An industrial control panel must not be installed if the short-circuit current rating is not equal to or greater than the available fault current and the voltage of this rating is not equal or greater than the system voltage. To facilitate this process, the available fault current calculation and date of calculation must be made available to the installer as well as to the inspector and maintainer.

If an existing industrial control panel is moved within a facility or to another facility, it is considered a new installation. Someone must calculate the available fault current and document it and the date of the calculation. This information must be made available to the installer and the installer can only install the industrial control panel if the SCCR is equal to or greater than the available fault current.

An AHJ must verify the industrial control panel installation complies with the NEC, including 409.22. See the NEC definition for AHJ including the Informational Note. In some cases, the AHJ may be an employee of the company where the industrial control panel is being installed

### Related NEC Sections

- Article 100 Fault current, available (available fault current) definition
- 110.10
- 409.110(4)
- Article 100 Authority Having Jurisdiction definition

### Change summary

- For consistency in the NEC, available fault current replaces available short-circuit current
- Documentation of available fault current and calculation date must also be made available to installers and maintainers

**NEC 110.10**

NEC 110.10 does not require equipment to be marked with its SCCR. However, there are several NEC requirements for various equipment types that do require SCCR marking, such as 409.110(4). These other NEC requirements complement the 110.10 requirement by being more prescriptive. Requiring equipment to be marked with its SCCR greatly simplifies the equipment short-circuit protection compliance process. To comply simply means, the equipment SCCR at specific voltage rating must be equal to or greater than the available fault current and system voltage must not exceed the SCCR specific voltage rating

**Marked SCCR**

With listed equipment, compliance with 110.10 corresponds to the meaning of its last sentence "...Listed equipment applied in accordance with their listing shall be considered to meet the requirements of this section." If the equipment is listed to a product standard that requires its SCCR to be marked, and if the installation complies with the equipment SCCR marking, then the installation complies with 110.10.

Additionally, 110.3(B) requires the equipment to be installed in accordance with instructions included in the listing or labeling. This means, that for both 110.10 and 110.3(B), the marked equipment SCCR in amps must be equal to or greater than the available fault current along with SCCR rated voltage equal to or greater than the nominal system voltage.

If the equipment SCCR is conditional on a specific overcurrent protective device amp rating or specific type overcurrent protective device, the proper overcurrent protective device must be used. It is common that some electrical equipment types may have multiple SCCRs that are conditional. The conditions are typically based on the type of OCPD feeding the equipment. The SCCR may be significantly higher when protected by current-limiting OCPDs.

**More resources**

**Calculating available fault current**

- FC<sup>2</sup> Available Fault Current Calculator (no cost): available from the app store or on-line [www.cooperbussmann.com/FC2](http://www.cooperbussmann.com/FC2)
- Point-to-point fault current calculation method in Selecting Protective Devices handbook [www.cooperbussmann.com/spd](http://www.cooperbussmann.com/spd) provides the equations and necessary data to calculate available fault current using calculator



**Industrial control panel SCCR**

- Bussmann series 2017 Code Changes Affecting SCCR pdf: [http://www.cooperindustries.com/content/public/en/bussmann/electrical/resources/library/technical\\_literature.html](http://www.cooperindustries.com/content/public/en/bussmann/electrical/resources/library/technical_literature.html)
- Bussmann series [Selecting Protective Devices \(SPD\) Handbook](#): entire section on industrial control panel SCCR

**Solution or products**

[\(See page 60 for product options\)](#)



**LPJ-SP**

600 V, 1 to 600 A  
time-delay Class J

Easily mounts in Class J holders, blocks and switches



**CUBEFuse**

600 V, 1 to 400 A  
time-delay Class CF

Compact, finger-safe design mounts in holders and CCP-CF switches

Bussmann series branch circuit fuses offer high interrupting ratings up to 300 kA.



**PDBFS\_**

200 kA SCCR finger-safe, DIN-Rail mount 600 V modular power distribution blocks up to 760 A



**CHCC and CH\_J**



**TCF\_H**



**CCP2-\_-30CC and CCP2-\_-CF**

200 kA, 600 V  
UL Listed disconnects; Class CC and CF fuses up to 200 A.

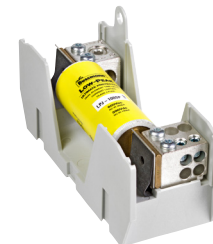

**JM600\_-MW\_**

200 kA SCCR, 600 V Class J ferrule and knifeblade modular power distribution fuse blocks up to 400 A. Optional covers provide IP20 protection.

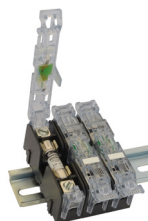

**BCM603\_-**

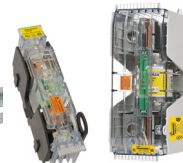

**RM\_-\_- JM60\_-\_-**

Finger-safe fuse holders and blocks increase electrical safety.

**Data sheets:** [LPJ- SP](#), [CUBEFuse](#), [PDBFS](#), [CHCC](#), [CH\\_J](#), [TCF\\_H](#), [BCM603](#), [JM60](#), [CCP](#), [JM600](#)

## Part III Motor and Branch-Circuit Overload Protection

## Article 430 Motors, Motor Circuits, and Controllers

## Chapter 4 Equipment for General Use

## 430.2 Definitions

**Electronically Protected (as applied to motors)**

The words “electronically protected” appearing on the nameplate of a motor indicate that the motor is provided with electronic control that is an integral part of the motor and protects the motor against dangerous overheating due to failure of the electronic control, overload and failure to start.

**430.32 Continuous-Duty Motors**

(A) More Than 1 Horsepower.

(2) Thermal Protector or Electronically Protected.

A thermal protector integral with the motor, shall be approved for use with the motor it protects on the basis that it will prevent dangerous overheating of the motor due to overload and failure to start. An electronically protected motor shall be approved for use on the basis that it will prevent dangerous overheating due to the failure of the electronic control, overload, or failure to start the motor. The ultimate trip current of a thermally or electronically protected motor shall not exceed the following percentage of motor full-load current given in Table 430.248, Table 430.249, and Table 430.250:

Motor full-load current 9 amperes or less 170%

Motor full-load current from 9.1 to, and including, 20 amperes 156%

Motor full-load current greater than 20 amperes 140%

If the motor current-interrupting device is separate from the motor and its control circuit is operated by a protective device integral with the motor, it shall be arranged so that the opening of the control circuit will result in interruption of current to the motor.



## Significance of the change

“Electronically protected” is an overload protection type for motors and motor branch circuits added for continuous duty motors under 430.32(A) for motors more than one hp and 430.32(B) for motors one hp or less and automatically started. The definition for “electronically protected (as applied to motors)” is added to 430.2. In addition, not shown above, 430.7(A)(16) is new and requires electronically protected motors to be marked “electronically protected” or “EP”.

This type of protection, that is an integral part of the motor, is commonly used in end use equipment in which manufacturers provide electronically protected motor(s), motor controller(s), internal wiring and main overcurrent protective device as listed and labeled assemblies marked with a short-circuit current rating.

These new additions were made because electronically protected motors are being installed stand-alone at the building site (not as part of completely assembled end use product). An installer provides and installs the individual motor circuit components and EP motor. In many cases, a motor controller for manual or automatic on/off control is part of the motor branch circuit and this controller can be used as the overload interrupting device as part of the electronically protected motor system. This means the motor circuit for an EP motor likely will not have a separate motor overload heater element device or other discrete motor overload sensing protection device external of the motor. In this case, the motor circuit consists of motor branch circuit disconnect, motor branch circuit short-circuit protective device, motor controller, and EP motor.

The designer and installer must ensure the motor controller short-circuit current rating is adequate for the installation. The motor controller markings or instructions for SCCR may specify specific motor branch circuit protective device requirements.

## Change summary

- New definition “electronically protected (as applied to motors)”
- Added motor marking requirement when electronically protected (EP)
- Added “electronically protected” as category of motor overload protection in 430.32

### Related NEC Sections

- 430.2 Definition “Electronically Protected”
- 430.7 Marking
- 430.32(A)(2)
- 430.32(B)(2)

**430.98 Marking**

(A) Motor Control Centers. Motor control centers shall be marked according to 110.21, and the marking shall be plainly visible after installation. Marking shall also include common power bus current rating and motor control center short-circuit current rating.

(B) Motor Control Units. ...

**430.99 Available Fault Current**

The available short-circuit fault current at the motor control center and the date the short-circuit available fault current calculation was performed shall be documented and made available to those authorized to inspect, install, or maintain the installation.



Manufacturer's nameplate with MCC SCCR marking: 65,000 A rms sym at 600V max.

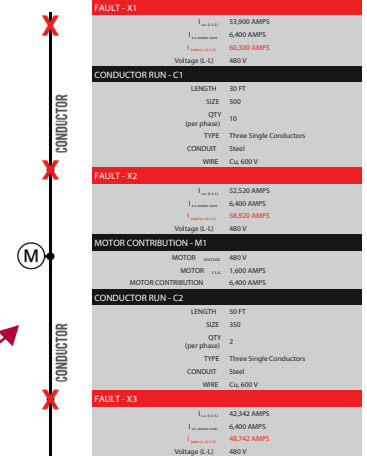

Documentation for available fault current and calculation date - example via Bussmann series FC<sup>2</sup> Available Fault Current Calculator.

**Significance of the change**

430.98 and 430.99 complement each other to help ensure Motor Control Centers (MCCs) are installed with the proper short-circuit current rating (SCCR).

430.98 is revised by adding "current" so that the SCCR terminology is proper. The MCC manufacturer must mark the SCCR on the assembly. The SCCR is typically designated as a RMS symmetrical amperes value at a specific voltage value.

430.99 has three revisions. "Available fault current" replaces "available short-circuit current" and "available fault current calculation" replaces "short-circuit current calculation" to align with an effort to have consistency in terminology throughout the NEC. The term "available fault current" is a new definition added to Article 100. The intent is it replaces 'available short-circuit current,' 'maximum available fault current', and other similar terms which were used but not defined in the NEC.

The third revision to 430.99 is the requirement the available fault current calculation should also be available to those who install and maintain the MCC. It is important that the installer know the available fault current at the MCC's installation point, so the installer can ensure that the MCC's SCCR is equal or greater than the available fault current in compliance with 110.10. Similarly, the maintainer needs access to this data to assess if the available fault current is still valid and confirm the MCC's SCCR is adequate for the installation. When parts are substituted in the MCC, such as replacing a motor starter or OCPD, it is imperative that the replacement part not reduce the MCC's SCCR below the marked SCCR.

**Related NEC Sections**

- 110.10
- "Available fault current" definition
- Numerous similar marking or documenting NEC requirements for other equipment

**Change summary**

- 430.98 adds "current" for proper "short-circuit current rating" terminology
- 430.99 revised to "available fault current" and "available fault current calculation"
- 430.99 expanded those persons who must have access to available fault current documentation to include installers and maintainers

## 440.10 Short-Circuit Current Rating

### Part I General

#### Article 440 Air-Conditioning and Refrigerating Equipment

##### Chapter 4 Equipment for General Use

REVISION

#### (A) Installation

Motor controllers or industrial control panels of multimotor and combination-load equipment shall not be installed where the available short-circuit fault current exceeds its short-circuit current rating as marked in accordance with 440.4(B).

#### (B) Documentation

When motor controllers or industrial control panels of multimotor and combination-load equipment are required to be marked with a short circuit current rating, the available short circuit fault current and the date the short circuit available fault current calculation was performed shall be documented and made available to those authorized to inspect, install, or maintain the installation.



### Significance of the change

This equipment typically has an equipment panel that contains the power circuit and control components. This equipment panel by definition is an “industrial control panel” and 440.10(A) now explicitly includes this term, which then correlates with 440.4(B) and 440.10(B). It also clarifies the SCCR is assigned to the motor controllers or industrial control panel.

Since installers and maintenance personnel may need to know the available fault current as well as when and how it was calculated, 440.10(B) requires this documentation to be shared with authorized installer and maintenance personnel.

Both 440.10(A) and (B) were revised: “Available fault current” replaces “available short-circuit current” and “available fault current calculation” replaces “short-circuit current calculation” to align with an effort to have consistency in terminology throughout the NEC. The term “available fault current” is a new definition added to Article 100. The intent is it replaces ‘available short-circuit current’ ‘maximum available fault current’, and other similar terms that were used but not defined in the NEC.

440.10(A) and 440.10(B) complement each other to ensure air conditioning and refrigeration equipment are installed with a short-circuit current rating (SCCR) equal to or greater than the available fault current. If the marked SCCR of equipment does not equal or exceed the available fault current, then the equipment shall not be installed.

### Change summary

- 440.10(A) added “industrial control panels”; which now correlate with 440.4(B) and 440.10(B)
- 440.10 terms revised to “available fault current” and “available fault current calculation”
- 440.10(B) expanded those who must have access to fault current documentation to include installers and maintainers

#### Related NEC Sections

- 110.10
- Article 100 definition “available fault current”
- 440.4(B)



**590.8 Overcurrent Protective Devices**

**A) Where Reused**

Where overcurrent protective devices that have been previously used are installed in a temporary installation, these overcurrent protective devices shall be examined to ensure these devices have been properly installed, properly maintained, and there is no evidence of impending failure.

**(B) Service Overcurrent Protective Devices**

Overcurrent protective devices for solidly grounded wye electrical services of more than 150 volts to ground but not exceeding 1000 volts phase-to-phase shall be current limiting.

Informational Note: The phrase “evidence of impending failure” means that there is evidence such as arcing, overheating, loose or bound equipment parts, visible damage, or deterioration. The phrase “properly maintained” means that the equipment has been maintained in accordance with the manufacturers’ recommendations and applicable industry codes and standards. References for manufacturers’ recommendations and applicable industry codes and standards include but are not limited to NEMA AB 4-2017, Guidelines for Inspection and Preventative Maintenance of Molded-Case Circuit Breakers Used in Commercial and Industrial Applications; NFPA 70B-2019, Recommended Practice for Electrical Equipment Maintenance; NEMA GD 1-2016, Evaluating Water-Damaged Electrical Equipment; and IEEE 1458-2017, IEEE Recommended Practice for the Selection, Field Testing, and Life Expectancy of Molded-Case Circuit Breakers for Industrial Applications.

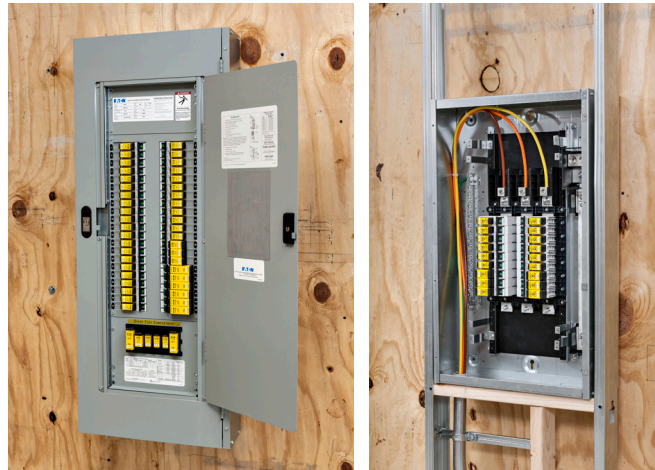

The Bussmann series Quik-Spec Coordination Panelboard with current-limiting Class CF CUBEFuse overcurrent protection.

**Significance of the change**

**590.8(A):** It is typical that temporary equipment is subject to much harsher conditions than permanently installed electrical equipment and these new requirements will contribute to better temporary overcurrent circuit protection and safety. In many cases, temporary OCPDs are installed in unconditioned environments subject to dust, wide swings in temperature, humidity, and resulting condensation. The equipment is put up, taken down, and transported from site to site or storage, which can contribute to additional physical conditions unlike permanently installed equipment. Wire terminations are made and changed many times. In addition, the likelihood that overcurrent devices in temporary panels would have to operate under short-circuit conditions is increased during the use of these panels. For instance, improper wiring may occur that creates a short-circuit condition. When circuit breakers operate under a short-circuit condition, they should be evaluated for continued use.

Now per 590.8(A), prior to energization for re-use, the OCPDs must be examined for proper installation and verifying they can provide overcurrent protection to manufacturers’ specifications.

The contractor or owner of the temporary equipment needs a means to verify compliance to the AHJ. The Information Note provides sources for recommendations on proper maintenance and investigating OCPDs to ensure they should operate properly. NFPA 70B 11.27 recommends a test or calibration decal system and record keeping for communicating vital equipment condition. After device testing or calibration, a decal on equipment in conjunction with test records, can communicate the condition of electrical equipment. An issue with temporary equipment is the intervals for performing the necessary evaluations is much more frequent.

**590.8(B):** Now temporary service overcurrent protective devices for typically 480/277 V systems must be current-limiting. This will provide added safety since temporary service equipment is routinely installed close to the utility transformers which may have lower impedance resulting in high available fault currents.

General for Temporary Equipment: The general 110.9 and 110.10 requirements for adequate OCPD interrupting ratings and equipment short-circuit current ratings are applicable and the AHJ should confirm compliance. In addition,

- New 408.6 requires the available fault current and date of the calculation be marked on temporary panelboards, switchboards, and switchgear. This equipment must have a short-circuit current rating equal to or greater than the available fault current.
- 230.62(C) requires service equipment to have barriers on the service uninsulated bus or terminations.

**Change summary**

- Previously used overcurrent protective devices (OCPDs) must be investigated to ensure their condition is suitable to be reused in temporary electrical systems
- Informational Note provides insightful material to aid the investigation
- Current-limiting OCPDs must be used as service OCPDs for solidly grounded wye electrical services of more than 150 volts to ground but not exceeding 1000 volts phase-to-phase

**Related NEC Sections**

- 110.9
- 110.10
- 408.6
- 230.62(C)

The greatest damage done to components by a fault current often occurs in the first half-cycle. Current-limiting OCPDs provide superior short-circuit protection by reducing thermal and mechanical stresses on conductors and equipment during a short-circuit condition. In addition, current-limiting OCPDs may reduce arc flash hazards.

There is a wide variation in the degrees of current-limiting capabilities for various overcurrent protective devices. For general electrical distribution systems, Bussmann series Low-Peak™ fuses provide the ultimate current-limiting protection.

**OCPDs marked current-limiting**

Not all OCPDs are current-limiting. Even when an OCPD is current-limiting, there are different degrees of current limitation. If a 600 V or less branch-circuit OCPD is current-limiting, it will be marked “current-limiting.”

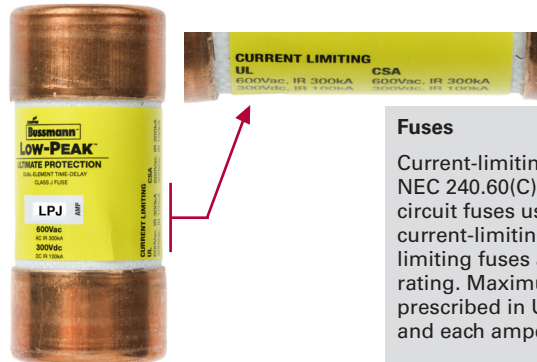

**Fuses**  
 Current-limiting fuses must be marked as such per NEC 240.60(C) as well as per UL 248. Most branch-circuit fuses used in electrical systems today are current-limiting. The requirements for current-limiting fuses are based on the fuse type/amp rating. Maximum  $I_{peak}$  and  $I^2t$  let-through values are prescribed in UL 248 for each different UL fuse class and each ampere rating.

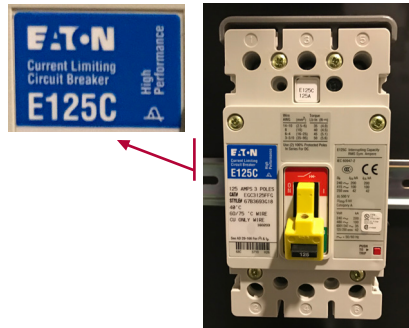

**Circuit breakers**  
 A molded case circuit breaker can be labeled current-limiting only if it meets the requirements of UL/CSA (489/22.2 No. 5). The only requirement for molded case circuit breakers to be marked current-limiting is that the device must limit the peak asymmetrical fault current to a value below the equivalent peak symmetrical fault current and clear within a 1/2 cycle.

**Solution or products**

[\(See page 60 for product options\)](#)

Current-limiting fuses are a good overcurrent protective device choice for temporary installations:

- Minimal maintenance
  - Check - no indication of water ingress
  - Check - fuse terminations or fuse body have no indication of overheating due to loose connection, degraded fuse clips, incorrect conductor size, etc.
  - Check continuity of fuses with ohmmeter
  - Check the physical integrity of fuse body, clips, blades, etc, to ensure that the fuses have not been damaged due to mishandling
- Greatly reduces life-cycle cost of temporary assemblies such as panelboards being used on multiple projects due to minimal maintenance while retaining reliable overcurrent protection
- High interrupting rating of 200,000 A or 300,000 A sym RMS at rated voltage
  - Alleviate concern for high available fault current installations – can use on all projects
- Fusible panelboards and switchboards utilizing current-limiting fuses typically have short-circuit current ratings of 200,000 A, 100,000 A, or 50,000 A sym RMS at rated voltage
- Current-limiting ability:
  - Reduces the damage incurred by fault current
  - Reduces violent whipping by loose temporary cables run on the project under short-circuit conditions
  - May mitigate the incident energy if an arc flash incident occurs

Fusible assemblies are available that can be equipped to only accept current-limiting fuses, as required per 240.60(B).

Fusible power distribution panelboards and switchboards are available from all the major electrical equipment manufacturers and independent assembly shops



**Quik-Spec Coordination Panelboard**  
 30, 60, 100, 200, 400A panelboards Utilize Compact Circuit Protector (CCP Switch) with current limiting CUBEFuses, 600V or less, 1 to 100A for branch circuits



**CUBEFuse** 600 Vac, 1 to 100 A Class CF  
**LPJ- SP** 600 Vac, 1 to 600 A Class J  
**LPS-RK- SP** 600 Vac, 1/10 to 600 A Class RK1  
**KRP-C- SP** 600 Vac, 601 to 6000 A Class L

- Data sheets:**
- [QSCP](#)
  - [CUBEFuse](#)
  - [LPJ- SP](#)
  - [LPS-RK- SP](#)
  - [KRP-C- SP](#)

## 620.51 Disconnecting Means

### Part VI Disconnecting Means and Control

#### Article 620 Elevators, Dumbwaiters, Escalators, Moving Walks, Platform Lifts, and Stairway Chairlifts

#### Chapter 6 Special Equipment

REVISION

##### (A) Type

The disconnecting means shall be an enclosed externally operable fused motor circuit switch or circuit breaker that is lockable only in the open position in accordance with 110.25.

The disconnecting means shall be a listed device.

Informational Note: For additional information, see ASME A17.1-2013/2016/CSA B44-13/16, *Safety Code for Elevators and Escalators*.

Exception No. 1: ...

Exception No. 2: ...

##### (D) Identification and Signs

###### (2) Available Short-Circuit Fault Current Field Marking.

Where an elevator control panel is used, it shall be legibly marked in the field with the maximum available short-circuit fault current at its line terminals. The field marking(s) shall include the date the short-circuit available fault current calculation was performed and be of sufficient durability to withstand the environment involved.

When modifications to the electrical installation occur that affect the maximum available short-circuit fault current at the elevator control panel, the maximum available short-circuit fault current shall be verified or recalculated as necessary to ensure the elevator control panel's short-circuit current rating is sufficient for the maximum available short-circuit fault current at the line terminals of the equipment. The required field marking(s) shall be adjusted to reflect the new level of maximum available short-circuit fault current.

##### (E) Surge Protection.

Where any of the disconnecting means in 620.51 has been designated as supplying an emergency system load, a legally required system load, or a critical operation power system load, listed surge protection shall be provided.



Bussmann series Quik-Spec Power Module switch and panel all-in-one elevator disconnects with shunt trip and fire safety interface provide a single point tie in with fire alarm systems.

## Significance of the change

The elevator disconnect must be capable of being locked in the open position and not capable of being locked in the closed position to avoid possible injury to technicians or passengers. This change was prompted by PI3622, which was endorsed by the ASME A17.1 Elevator and Escalator Committee, and the National Elevator Industry, Inc. (NEII) Central Code Committee.

"Available fault current" replaces "maximum available short-circuit current" and "available short-circuit current" to align with an effort to have consistency in terminology throughout the NEC. The term "available fault current" is a new definition added to Article 100. It is intended to replace "available short-circuit current," "maximum available fault current," and other similar terms that were used but not defined in the NEC.

Now any elevator, dumbwaiter, escalator, moving walk, platform lift, and stairway chairlift disconnects covered in 620.51 supplying loads in emergency systems, legally required systems, or a critical operation power systems must have surge protection.

## Change summary

- Elevator disconnect must be lockable only in open position and not closed position
- Terminology changed to "available fault current" from "maximum available short-circuit current" and "available short-circuit current"
- Any elevator, dumbwaiter, escalator, moving walk, platform lift, and stairway chairlift disconnecting means in 620.51 supplying loads in emergency system, legally required system, or a critical operation power system must have surge protection

## Solution or products



See [data sheet 1145](#)

Power module elevator disconnect installation videos at [Eaton.com/bussmannseries](http://Eaton.com/bussmannseries)

### Related NEC Sections

- 110.10
- "Available fault current" definition
- Numerous similar marking or documenting NEC requirements for other equipment
- Article 242

## 620.62 Selective Coordination

### Part VII Overcurrent Protection

#### Article 620 Elevators, Dumbwaiters, Escalators, Moving Walks, Platform Lifts, and Stairway Chairlifts

#### Chapter 6 Special Equipment

REVISION

#### 620.62 Selective Coordination

Where more than one driving machine disconnecting means is supplied by a single-feeder the same source, the overcurrent protective devices in each disconnecting means shall be selectively coordinated with any other supply side overcurrent protective devices.

Selective coordination shall be selected by a licensed professional engineer or other qualified person engaged primarily in the design, installation, or maintenance of electrical systems. The selection and device settings shall be documented and made available to those authorized to design, install, inspect, maintain, and operate the system.

Exception No. 1: Selective coordination shall not be required between transformer primary and secondary overcurrent protective devices where only one overcurrent device or set of overcurrent devices exists on the transformer secondary.

Exception No. 2: Selective coordination shall not be required between overcurrent protective devices of the same rating located in series where no loads are connected in parallel with the downstream device.

#### Related NEC Sections

- Definition for selective coordination
- 700.32

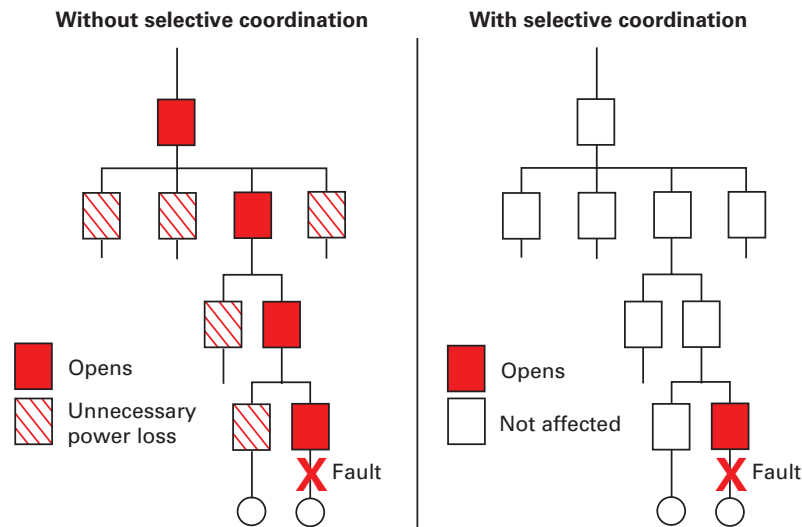

Selective coordination isolates the circuit's faulted portion and only the faulted portion. The OCPD closest to the fault is the only device to open to limit the impact on the balance of the system.

### Significance of the change

If there is more than one elevator, dumbwaiter, escalator, moving walk, platform lift, and/or stairway chairlift driving machine disconnecting means supplied by the same source, then the overcurrent protective devices must be selectively coordinated with all supply side overcurrent protective devices. For instance, if a building served by a utility has one service that supplies an elevator and an escalator, then the driving machine disconnecting means overcurrent protective devices for each must be selectively coordinated with all supply side overcurrent protective devices.

The documentation that provides the specifics on how selective coordination is achieved for applicable circuits and which is required to be available to the AHJ, installer, designer, maintainer, and system operator, must now include the overcurrent protective device type, ampere rating and, if circuit breakers, the settings. This is important so that the party responsible for procuring and installing the overcurrent protective devices has the proper information to ensure it is done as designed. For instance, for circuit breakers, with this specific setting documentation, the AHJ can verify installed circuit breaker settings are as specified in the selective coordination documentation.

The two new exceptions are not necessary since the Article 100 selective coordination definition encompasses the two exceptions. However, the inclusion of the exceptions helps those who are less knowledgeable on the application of achieving selective coordination.

### Change summary

- If there are two or more elevators, dumbwaiters, escalators, moving walks, platform lifts, or stairway chairlifts supplied by the same source, the disconnecting means overcurrent protective devices shall be selectively coordinated with any supply side OCPD
- The documentation for the specific overcurrent protective devices to achieve selective coordination must include the device settings
- Two new exceptions clarify selective coordination requirement for the less knowledgeable

Bussmann series Quik-Spec Power Module elevator disconnect and Eaton's Elevator Disconnect are simple and consistent Listed installation solutions for complying with numerous NEC, ASME, and NFPA 72 requirements. In one enclosure, engineering consultants and contractors can comply with the 620.62 NEC requirement for selective coordination, ASME 17.1 shunt-trip requirement, and NFPA 72 fire safety interface and monitoring requirements. When sprinklers are installed in elevator hoistways, machine rooms, or machinery spaces, ANSI/ASME A17.1 requires that the power be removed to the affected elevator upon or prior to the activation of these sprinklers. This is most commonly accomplished using a shunt-trip disconnect with its own control power. In addition, interface with the fire alarm system, along with the monitoring of components required by NFPA 72, must be accomplished in order to activate the shunt-trip action when appropriate as well as helping to make sure that the system is functional during normal operation. This requires the use of interposing relays that are supplied in other equipment.

## More resources

### Calculating available fault current

Selecting Protective Devices handbook  
[www.cooperbussmann.com/spd](http://www.cooperbussmann.com/spd) sections on:

- Fuse-to-fuse selectivity ratio guide table
- Circuit breaker-to-fuse selective coordination tables

## Solution or products

### Power Module Switch fusible elevator disconnect:



Bussmann series Quik-Spec Power Module Switch for single elevator applications.

[Product profile No. 10268](#)

### Power Module Panel fusible elevator panelboard:



Bussmann series Quik-Spec Power Module Panel for multiple elevator applications

[Product profile No. 10269](#) - 400 A - 800 A  
[Product profile No. 3187](#) - 600 A - 1200 A



Eaton elevator disconnect for single elevator applications.

Consulting Application Guide No. 22.6-11



Eaton elevator control panelboard for multiple elevator applications.

Consulting Application Guide No. 28.0-7

## 620.65 Signage

### Part VII Overcurrent Protection

#### Article 620 Elevators, Dumbwaiters, Escalators, Moving Walks, Platform Lifts, and Stairway Chairlifts

#### Chapter 6 Special Equipment

**NEW**

#### 620.65 Signage

Equipment enclosures containing selectively coordinated overcurrent devices shall be legibly marked in the field to indicate that the overcurrent devices are selectively coordinated. The marking shall meet the requirements of 110.21(B), shall be readily visible, and shall state the following: CAUTION: OVERCURRENT DEVICES IN THIS ENCLOSURE ARE SELECTIVELY COORDINATED. EQUIVALENT REPLACEMENTS AND TRIP SETTINGS ARE REQUIRED.



### Significance of the change

New marking requirement to help ensure service and maintenance personnel are alerted that the overcurrent protective devices in the enclosure are selectively coordinated with other overcurrent protective devices. The text of the marking cautions that any replacement overcurrent protective devices must be equivalent so selective coordination is retained. The replacements should be the exact same manufacturer's product part and, for an adjustable circuit breaker, the settings must also be exactly the same. A different overcurrent protective device part number and/or manufacturer's product can only be used as a replacement if a person qualified in the selection of overcurrent protective devices that are selectively coordinated does an analysis and selects overcurrent protective devices that are selectively coordinated.

### Change summary

- New field marking requirement notifying that the overcurrent protective devices are selectively coordinated with other overcurrent protective devices

#### Related NEC Sections

- 620.62
- Article 100 selective coordination definition
- 110.21(B)

**645.27 Selective Coordination**

Critical operations data system(s) overcurrent protective devices shall be selectively coordinated with all supply-side overcurrent protective devices.

Selective coordination shall be selected by a licensed professional engineer or other qualified persons engaged primarily in the design, installation, or maintenance of electrical systems. The selection shall be documented and made available to those authorized to design, install, inspect, maintain, and operate the system.

**Significance of the change**

The new text better aligns with other NEC sections that require selective coordination. The core requirement that all critical operation power system circuit overcurrent protective devices must be selectively coordinated remains unchanged.

The person selecting the overcurrent protective devices (and settings, if adjustable circuit breakers), must be qualified for the task of making selections that achieve selective coordination. This task requires specific knowledge and skills. In addition, the new text makes it clear that the selection made by the qualified person must be documented and the documentation must be made available to other disciplines involved in the process from design to maintenance. This documentation is critical so the AHJ has documented verification that selective coordination has been achieved and the AHJ can have the overcurrent protective device selections, including settings, verified or spot verified.

**Change summary**

- Person selecting the overcurrent protective devices that are selectively coordinated must be qualified for this task
- The documentation showing the selection of overcurrent protective devices to achieve selective coordination must be made available to the disciplines noted

**Related NEC Sections**

- Article 100 selective coordination definition
- Numerous other sections requiring selective coordination

**670.5 Short-Circuit Current Rating**

(1) Industrial machinery shall not be installed where the available ~~short-circuit fault~~ short-circuit fault current exceeds its short-circuit current rating as marked in accordance with 670.3(A)(4).

(2) Industrial machinery shall be legibly marked in the field with the ~~maximum~~ available fault current. The field marking(s) shall include the date the ~~short-circuit~~ available fault current calculation was performed and be of sufficient durability to withstand the environment involved.



**Significance of the change**

“Available fault current” replaces “maximum available short-circuit current” and “available short-circuit current” to align with an effort to have consistency in terminology throughout the NEC. The term “available fault current” is a new definition added to Article 100. It is intended to replace “available short-circuit current,” “maximum available fault current,” and other similar terms that were used but not defined in the NEC.

670.5 is an important industrial machinery requirement for safety under short-circuit conditions with the following requirements working together:

- 670.3(A)(4): Nameplate of the machine industrial control panel must be marked with short-circuit current rating (SCCR)
- 670.5(2): Field mark the industrial machinery with the available fault current at point of installation
- 670.5(1): If the SCCR is less than the available fault current, the industrial machinery shall not be installed

**Change summary**

- Terminology changed to “available fault current” from “maximum available short-circuit current” and “available short-circuit current”

**Related NEC Sections**

- Article 100 definition for “available fault current”
- 110.9
- 110.10
- 409.22 and 409.110(4)



## 695.3(C)(3) Selective Coordination

### 695.3 Power Source(s) for Electric Motor-Driven Fire Pumps

#### Article 695 Fire Pumps

#### Chapter 6 Special Equipment

REVISION

#### (C) Multibuilding Campus-Style Complexes

If the sources in 695.3(A) are not practicable and the installation is part of a multibuilding campus-style complex, feeder sources shall be permitted if approved by the authority having jurisdiction and installed in accordance with either 695.3(C)(1) and (C)(3) or (C)(2) and (C)(3).

#### (1) Feeder Sources

Two or more feeders shall be permitted as more than one power source if such feeders are connected to, or derived from, separate utility services. The connection(s), overcurrent protective device(s), and disconnecting means for such feeders shall meet the requirements of 695.4(B)(1) (b).

#### (2) Feeder and Alternate Source

A feeder shall be permitted as a normal source of power if an alternate source of power independent from the feeder is provided. The connection(s), overcurrent protective device(s), and disconnecting means for such feeders shall meet the requirements of 695.4(B)(1) (b).

#### (3) Selective Coordination

~~The overcurrent protective device(s) in each disconnecting means shall be selectively coordinated with any other all supply-side overcurrent protective device(s).~~

Selective coordination shall be selected by a licensed professional engineer or other qualified persons engaged primarily in the design, installation, or maintenance of electrical systems. The selection shall be documented and made available to those authorized to design, install, maintain, and operate the system.

Exception: Selective coordination shall not be required between two overcurrent devices located in series if no loads are connected in parallel with the downstream device.



## Significance of the change

Article 695.3(C)(3) applies to multibuilding campus-style complexes and the requirements of 695.3(A) are not practical. If so, two or more feeders or a feeder and alternate source are permitted to supply a fire pump as stated in (C)(1) and (C)(2) if for these feeders, all the overcurrent protective devices in the current path from the fire pump to power source are selectively coordinated with all supply side overcurrent protective devices.

This revision aligns the selective coordination requirement text with many other sections such as 700.32.

The feeders permitted in 695.3(A) are required to be dedicated to a fire pump. However, the feeder or feeders in 695.5(C) do not have to be solely dedicated to a fire pump, hence the need for selective coordination.

It is important that a person qualified and skilled in selecting overcurrent protective devices that achieve selective coordination makes the selection and creates documentation. Others involved in the design, installation, inspection, and maintenance of the system must have access to the documentation.

The information in the exception is not necessary since this concept is incorporated in the definition. However, the exception helps those less knowledgeable in this subject and correlates with exceptions for selective coordination in other articles such as Article 700, 701 and 708.

## Change summary

- Clarifying edit to include 695.3 for 695.3(C)(1) and (C)(3) or (C)(2) and (C)(3)
- The selection of overcurrent protective devices (OCPDs) to achieve selective coordination must be made by a qualified person for this task
- Selection of OCPDs must be documented and available to other disciplines as noted
- Exception added for clarification

#### Related NEC Sections

- 700.32, 701.32, 708.54
- NFPA 20 section 9.2.2

**700.4 Capacity and Rating****(A) Capacity and Rating**

An emergency system shall have adequate capacity and rating for all loads to be operated simultaneously. The emergency system equipment shall be suitable for the maximum available fault current at its terminals.

**B) Capacity**

An emergency system shall have adequate capacity in accordance with Article 220 or by another approved method.

**(B)(C) Selective Load Pickup, Load Shedding, and Peak Load Shaving**

The alternate power source shall be permitted to supply emergency, legally required standby, and optional standby system loads where the source has adequate capacity or where automatic selective load pickup and load shedding is provided as needed to ensure adequate power to (1) the emergency circuits, (2) the legally required standby circuits, and (3) the optional standby circuits, in that order of priority. The alternate power source shall be permitted to be used for peak load shaving, provided these conditions are met.

Peak load shaving operation shall be permitted for satisfying the test requirement of 700.3(B), provided all other conditions of 700.3 are met.

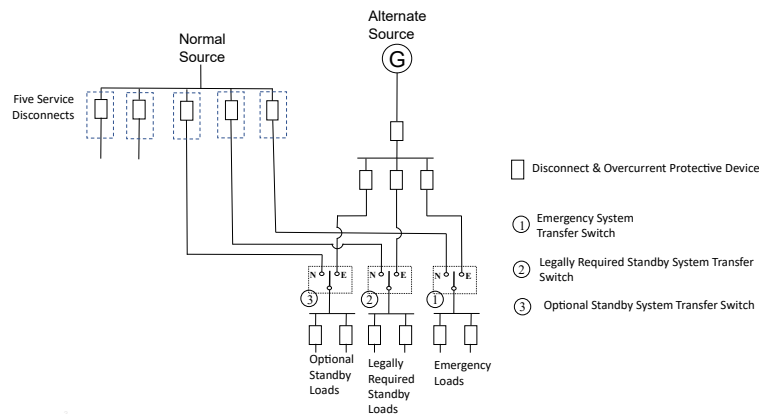

Per 700.4(A), 701.4(A), 702.4 for these three systems, all the overcurrent protective devices must have interrupting ratings and all the electrical equipment must have short-circuit current ratings equal to or greater than the higher available fault current from either the normal source or alternate source.

**Significance of the change**

The organization of 700.4 is improved by subdividing this section into A, B and C.

(A) Ratings is revised to use the newly defined term “available fault current,” which helps provide terminology consistency throughout the NEC. It is important for safety and power reliability that all the overcurrent protective devices have interrupting ratings equal to or greater than the available fault current at their lineside terminals and other equipment have short-circuit current ratings equal to or greater than the available fault current at their lineside terminals.

The requirement to have adequate capacity to operate all loads simultaneously was deleted and is replaced by (B), which requires capacity in accordance with Article 220 or other approved method. The AHJ has purview as to what constitutes an acceptable approved method.

The requirements allocated to (C) have no revisions. However, when optional standby systems are supplied by the same alternate power source as the emergency system, any common OCPDs to both the emergency system and optional standby must comply with the selective coordination requirements of 700.10(B)(5)(b)(ii). See Informational Note Figure 700.10(B)(5)(b)(1).

**Change summary**

- 700.4 reorganized for clarity, separating prior (A) Capacity and Rating into (A) Rating and (B) Capacity
- (A) Rating revised by deleting “maximum” since term “available fault current” is defined as maximum
- Emergency system capacity requirement in (B) revised to be in accordance with Article 220 or another approved method
- (C) text has no changes

**Related NEC Sections**

- 701.4
- 702.4
- Article 220
- Available Fault Current definition
- 110.9
- 110.10
- 700.10(B)(5)(b)(ii) and Informational Note Figure 700.10(B)(5)(b)(1)

**700.32 Selective Coordination**

Emergency system(s) overcurrent devices shall be selectively coordinated with all supply-side overcurrent protective devices. Selective coordination shall be selected by a licensed professional engineer or other qualified persons engaged primarily in the design, installation, or maintenance of electrical systems. The selection shall be documented and made available to those authorized to design, install, inspect, maintain, and operate the system.

*Exception: Selective coordination shall not be required between two overcurrent devices located in series if no loads are connected in parallel with the downstream device.*

Informational Note: See Informational Note Figure 700.32 for an example of how emergency system overcurrent protective devices (OCPDs) selectively coordinate with all supply-side OCPDs. OCPD D selectively coordinates with OCPDs C, F, E, B, and A. OCPD C selectively coordinates with OCPDs F, E, B, and A. OCPD F selectively coordinates with OCPD E. OCPD B is not required to selectively coordinate with OCPD A because OCPD B is not an emergency system OCPD. Figure Informational Note Figure 700.32 Emergency System Selective Coordination. (image shown to the right).

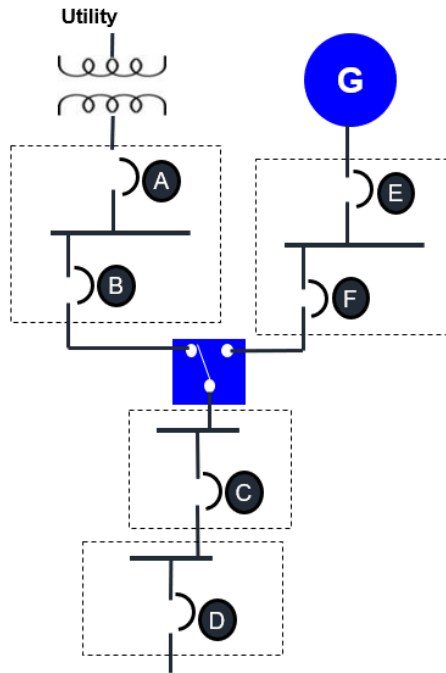

**Significance of the change**

The new Informational Note and associated Informational Note Figure illustrate an example of how the explicit language that each emergency system overcurrent protective device “shall be selectively coordinated with **all supply-side** overcurrent protective devices” is properly applied.

The burden is on each emergency system overcurrent protective device to selectively coordinate with:

- All supply-side emergency system OCPDs – these are OCPDs that are installed from the emergency system alternate source to the emergency loads.
- All OCPDs installed in the current path from the normal source to the lineside of the emergency system transfer switch.

Some people fail to recognize the subtlety of the emergency system OCPDs being required to selectively coordinate with the OCPDs installed in the current path from the normal source to the transfer switch, which is:

- The emergency system OCPDs must selectively coordinate with the OCPDs installed in the current path from the normal source to the transfer switch.
- However, an OCPD installed in the current path from the normal source to the transfer switch is not required to be selectively coordinated with any supply-side OCPD. Although not required, best engineering practice would be to have each normal source OCPD be selectively coordinated with all supply-side normal source OCPD.

**Related NEC Sections**

- Article 100 Selective coordination definition
- 620.62
- 620.65
- 645.27
- 695.3(C)(3)
- 700.10(B)(5)(b)(ii)
- 701.32
- 708.54

**Change summary**

- Informational Note and Informational Figure illustrate each emergency system OCPDs must selectively coordinate with all supply-side emergency system OCPDs and all supply-side OCPDs in the normal source path to the emergency system.

The term coordination study is commonly used in the industry. It does not ensure selective coordination is achieved. Normally, it points out where the overcurrent protective devices are selectively coordinated and where they are not selectively coordinated. It may include recommendations of how to achieve a higher degree of coordination or even how to obtain selective coordination. It may also include cable and transformer protection analysis.

For compliance with the selective coordination requirements in the NEC, AHJs require documentation from the responsible party that verifies the overcurrent protective devices are selectively coordinated per the definition in the NEC and to the specific requirement, such as 700.32. The documentation verifying selective coordination must provide the specific overcurrent protective device types, ampere ratings, characteristics, and, if adjustable circuit breakers, settings.

**More resources**

**Calculating available fault current**

Selecting Protective Devices handbook [www.cooperbusssmann.com/spd](http://www.cooperbusssmann.com/spd) sections on:

- Fuse-to-fuse selectivity ratio guide table
- Circuit breaker-to-fuse selective coordination tables
- Circuit breaker-to-circuit breaker selective coordination tables
- Electrical protection handbook, Selecting Protective Devices, sections on selective coordination and how to achieve selective coordination with fuses

**Solution or products**

**Fusible panelboards:**



Quik-Spec Coordination Panelboard

Pow-R-Line 3FQS

30, 60, 100, 200, 400 A panelboards utilize Compact Circuit Protector (CCP) with CUBEFuse, 600 V or less, 1 to 100 A for branch circuits

**Bussmann series Low-Peak fuses**

Selecting and installing fuses for a selectively coordinated electrical system is easy using Bussmann series Low-Peak fuses. Simply adhere to the published ampere rating ratios of 2:1. These ratios are applicable up to 200 kA available fault current for the Low-Peak fuses shown below. In addition, if the available fault currents on a system increase during the design to construction cycle or any time after energization, selective coordination is retained.



LP-CC-(amp) 1/2 to 30 A (600 V) Class CC	TCF(amp)RN 1 to 400 A (600 V) Class CF	LPJ-(amp)SP 1 to 600 A (600 V) Class J	LPS-RK-(amp)SP 1/10 to 600 A (600 V) Class RK1	LPN-RK-(amp)SP 1/10 to 600 A (250 V) Class RK1	KRP-C-(amp) SP 601 to 6000 A (600 V) Class L
---	---	---	---	---	---

**Data sheets:**

- [QSCP](#)
- [LP-CC](#)
- [CUBEFuse](#)
- [LPJ- SP](#)
- [LPS-RK- SP](#)
- [LPN-RK](#)
- [KRP-C- SP](#)

## 701.4 Capacity and Rating, (A) and (B)

### Part I General

### Article 701 Legally Required Standby Systems

### Chapter 7 Special Conditions

REVISION

#### 701.4 Capacity and Rating

(1) Where the alternate source has adequate capacity to handle all connected loads

(2) Where automatic selective load pickup and load shedding is provided that will ensure adequate power to the legally required standby circuits

#### (A) Rating

Legally required standby system equipment shall be suitable for the maximum available fault current at its terminals.

#### (B) Capacity

A legally required standby system shall have adequate capacity and rating for the supply of all equipment intended to be operated at one time in accordance with Article 220 or by another approved method.

#### (C) Load Pickup, Load Shedding, and Peak Load Shaving

The legally required standby alternate power source shall be permitted to supply both legally required standby and optional standby system loads under either of the following conditions: where the alternate source has adequate capacity or where automatic selective load pickup and load shedding are provided that will ensure adequate power to the legally required standby circuits.

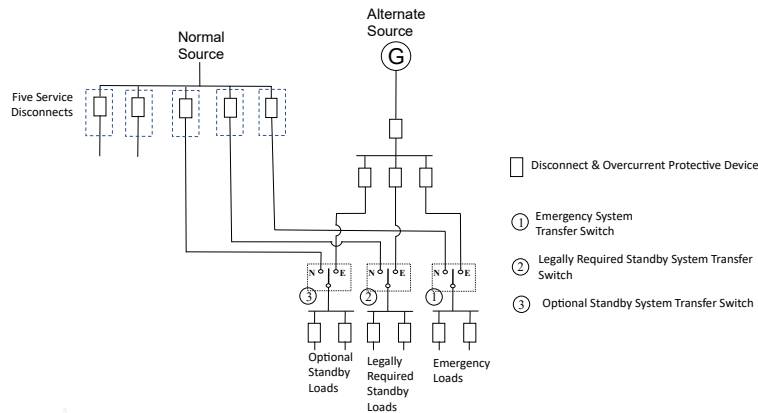

Per 700.4(A), 701.4(A), 702.4 for these three systems, all the overcurrent protective devices must have interrupting ratings and all the electrical equipment must have short-circuit current ratings equal to or greater than the higher available fault current from either the normal source or alternate source.

## Significance of the change

The organization of 701.4 is improved by subdividing this section into A, B and C.

(A) Ratings is revised to using the newly defined term “available fault current,” which helps provide terminology consistency throughout the NEC. “Maximum” deleted since the “available fault current” definition is the maximum. It is important for power reliability and safety that all the overcurrent protective devices have interrupting ratings equal to or greater than the available fault current at their terminals and other equipment has short-circuit current ratings equal to or greater than the available fault current at their terminals.

The requirement for the legally required systems to have adequate capacity to operate all loads simultaneously was deleted and is replaced by (B), which requires capacity in accordance with Article 220 or other approved method. The AHJ has purview as to what constitutes an acceptable approved method.

The requirements allocated to (C) permitting the alternate power source to supply both legally required standby system loads and optional system loads is restructured for better clarity.

## Change summary

- For clarity, section text reorganized into (A), (B), and (C) format
- “Maximum” deleted in (A) since available fault current is defined as maximum
- Legally required standby system capacity requirement in (B) revised to be in accordance with Article 220 or another approved method
- Text in (C) permitting alternate power source to supply legally required standby system loads and optional system loads restructured for better clarity

#### Related NEC Sections

- 700.4
- 702.4
- Article 220
- Available Fault Current definition
- 110.9
- 110.10

**701.31 701.26 Ground-Fault Protection of Equipment**  
 The alternate source for legally required standby systems shall not be required to provide ground-fault protection of equipment with automatic disconnecting means. Ground-fault indication at the legally required standby source shall be provided in accordance with 701.6(D) if ground-fault protection of equipment with automatic disconnecting means is not provided.

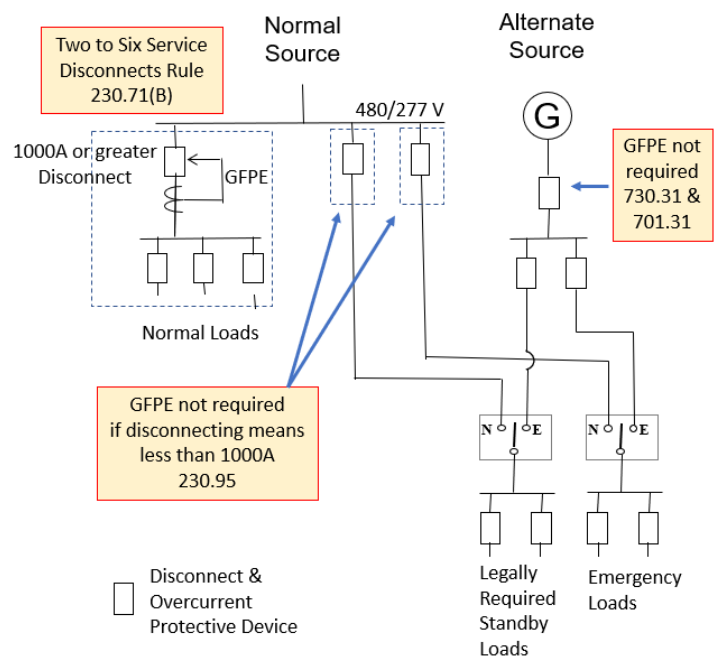

**Significance of the change**

The only change to this section is the section number to align with Article 700 section numbering scheme.

However, for increased power reliability by not having to install ground fault protection of equipment (GFPE), this section is important to highlight. Some designers want the option to avoid installing GFPE in the power circuits of legally required standby system. This is similar to 695.6(G), which does not permit GFPE to be installed in any fire pump power circuit.

Per 701.31, GFPE is not required for the alternate source of legally required standby systems. Continuity of power is important to the vital loads served by legally required standby system.

Similarly, it is important for the normal power source path supplying legally required standby systems to be as reliable as possible. In this case, 230.71(B) *Two to Six Service Disconnecting Means* provides a design option for higher reliability of the normal source path to the automatic transfer switch. With this option, since the disconnects are typically less than 1000 A, there are benefits including:

- For 480/277 V, solidly grounded wye systems, GFPE per 230.95 is not required.
- Additional arc energy reduction technology analysis and consideration per 240.67 and 240.87 are not required.

See the introduction section *Two to Six Service Disconnects and Service Terminal Barriers* in this publication.

See diagram above. 700.31 has the same requirement for the emergency systems.

**Related NEC Sections**

- 700.31
- 230.71(B)

**Change summary**

- Section number changed to align with Article 700 requirements organization

## 701.32 Selective Coordination

### Part VI Overcurrent Protection

#### Article 701 Legally Required Standby Systems

##### Chapter 7 Special Conditions

REVISION

#### 701.32 701.27 Selective Coordination

Legally required standby system(s) overcurrent devices shall be selectively coordinated with all supply-side overcurrent protective devices.

Selective coordination shall be selected by a licensed professional engineer or other qualified persons engaged primarily in the design, installation, or maintenance of electrical systems. The selection shall be documented and made available to those authorized to design, install, inspect, maintain, and operate the system.

*Exception: Selective coordination shall not be required between two overcurrent devices located in series if no loads are connected in parallel with the downstream device.*

Informational Note: See Informational Note Figure 701.32 for an example of how legally required standby system overcurrent protective devices (OCPDs) selectively coordinate with all supply-side OCPDs. OCPD D selectively coordinates with OCPDs C, F, E, B, and A. OCPD C selectively coordinates with OCPDs F, E, B, and A. OCPD F selectively coordinates with OCPD E. OCPD B is not required to selectively coordinate with OCPD A because OCPD B is not a legally required standby system OCPD. Figure Informational Note Figure 701.32 Legally Required Standby System Selective Coordination.

#### Related NEC Sections

- Selective coordination definition
- 620.62
- 620.65
- 645.27
- 695.3(C)(3)
- 700.32
- 708.54
- 700.10(B)(5)(b)(ii) and Informational Note Figure 700.10(B)(5)(b)(1)

See more information in discussion on 700.32 change and selective coordination in front of this publication.

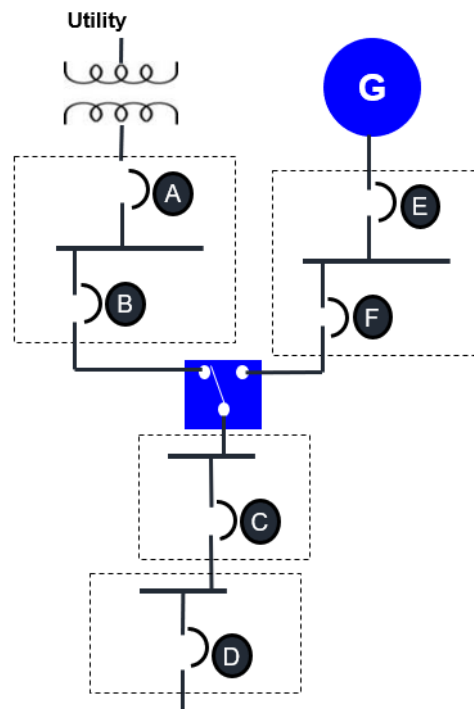

### Significance of the change

The new Informational Note and associated Informational Note Figure illustrate how the explicit language that each legally required standby system overcurrent protective device “shall be selectively coordinated with all supply-side overcurrent protective devices” is properly applied.

The burden is on each legally required standby system overcurrent protective device to selectively coordinate with:

- All supply-side legally required standby system OCPDs – these are OCPDs that are installed from the legally required standby system alternate source to the legally required standby loads.
- All OCPDs installed in the current path from the normal source to the lineside of the legally required standby transfer switch.

Some people fail to recognize the subtlety of the legally required standby system OCPDs being required to selectively coordinate with the OCPDs installed in the current path from the normal source to the transfer switch, which is:

- The legally required standby system OCPDs must selectively coordinate with the OCPDs installed in the current path from the normal source to the transfer switch.
- However, an OCPD installed in the current path from the normal source to the transfer switch is not required to be selectively coordinated with any supply-side OCPD. Although not required, best engineering practice would be to have each normal source OCPD selectively coordinated with all supply-side normal source OCPD.

### Change summary

- Informational Note and Informational Figure illustrate each legally required standby system OCPDs must selectively coordinate with all supply-side legally required standby OCPDs and all supply-side OCPDs in the normal source path to the legally required standby system.

## 702.4 Capacity and Rating, (A) Available Fault Current

### Part I General

### Article 702 Optional Standby Systems

### Chapter 7 Special Conditions

REVISION

#### 702.4 Capacity and Rating

##### (A) Available Short-Circuit Fault Current

Optional standby system equipment shall be suitable for the maximum available short-circuit fault current at its terminals.

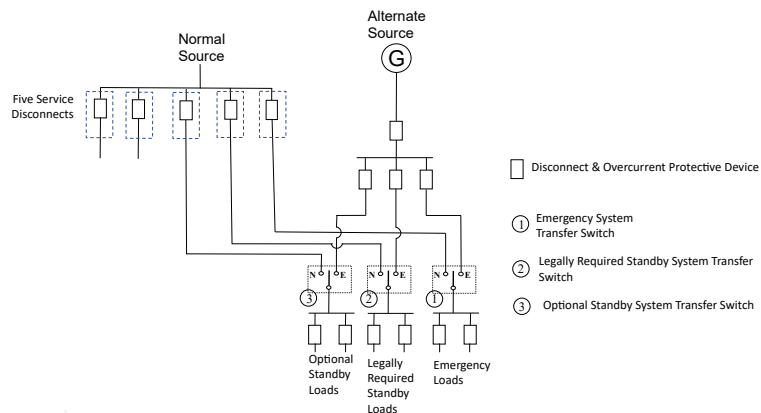

Per 700.4(A), 701.4(A), 702.4 for these three systems, all the overcurrent protective devices must have interrupting ratings and all the electrical equipment must have short-circuit current ratings equal to or greater than the higher available fault current from either the normal source or alternate source.

### Significance of the change

702.4(A) is revised to the newly defined term “available fault current,” which helps provide terminology consistency throughout the NEC. “Maximum” is deleted since the “available fault current” definition is the maximum. It is important for power reliability and safety that all the overcurrent protective devices have interrupting ratings equal to or greater than the available fault current at their line terminals and other equipment has short-circuit current ratings equal to or greater than the available fault current at their line terminals.

### Change summary

- Revised to “available fault current,” which is a newly defined term, to provide terminology consistency throughout NEC
- “Maximum” deleted since “available fault current” definition is the maximum

#### Related NEC Sections

- Available fault current definition
- 110.9
- 110.10



## Part I General

## Article 705 Interconnected Electric Power Production Sources

## Chapter 7 Special Conditions

### 705.11 Supply-Side Source Connections

An electric power production source, where connected on the supply side of the service disconnecting means as permitted in 230.82(6), shall comply with 705.11(A) through (F).

#### (A) Output Rating...

#### (B) Conductors...

#### (C) Overcurrent Protection

The power source output circuit conductors shall be protected from overcurrent in accordance with 705.28 and 705.30. If fuses are not integral with the disconnecting means the disconnecting means shall be located on the service side of the fuses. Where the power source output circuit conductors make their connection to the service outside of a building, they shall be protected by overcurrent devices in a readily accessible location outside the building or at the first readily accessible location where the power source conductors enter the building. Where the power source output circuit conductors make their connection to the service inside a building, they shall be protected with one of the following methods:

1. Within 5 m (16.5 ft). With an overcurrent device within 5 m (16.5 ft) of conductor length from the point of connection to the service
2. Within 20 m (71 ft). With cable limiters at the connection to the service and an overcurrent device located within 20 m (71 ft) of conductor length from the point of connection to the service



### Significance of the change

Former 705.12 supply-side connections requirements are moved to 705.11 and revised. Rather than making numerous references to Article 230 and Article 250, most of the requirements are specifically called out in the new 705.11.

This change discussion focuses only on 705.12(C) overcurrent protection for power source output circuit conductors connected to the service inside a building. In this situation, overcurrent protection is critical for safety. Two options are permitted:

1. An overcurrent protective device must be within no more than 16.5 feet of conductor length from the point of connection to the service (on supply-side of service disconnect). An example would be a fusible safety switch within the first 16.5 feet of conductor from the connection to the service.
2. The conductor length from the point of connection to the service (on supply-side of service disconnect) can be up to 71 feet without a branch-circuit rated fuse or circuit breaker, if each ungrounded conductor has a cable limiter installed at the point of connection to the service. Cable limiters can interrupt quickly and limit the current under short-circuit conditions. They are suitable for short-circuit protection for that portion of the circuit from the cable limiter to the location of branch circuit rated fuses or circuit breaker, which then are permitted to be installed up to 71 feet from the connection point to the service.

230.82(1) permits installing cable limiters on the supply-side of service disconnecting means and per 240.40, a disconnect is not required in conjunction with a cable limiter in this application.

### Change summary

- Former 705.12 supply-side connections are moved to 705.11 and revised
- Power source output circuit conductors connected to the service inside a building are permitted two options for overcurrent protection.

From the point conductors are connected to the service:

- Conductors must have branch circuit fuses or circuit breaker within first 16.5 feet
- Conductors can have branch circuit rated fuses or circuit breaker up to 71 feet away from the point of connection to the service, if the conductor has a cable limiter at the point of connection to service conductor

### Related NEC Sections

- 230.81(1)
- Article 230

**Figure 16** illustrates compliance to 705.11(C)(1). In this case, the service equipment is in a building (other than a dwelling unit) and the electric power production source output conductors are spliced to the service conductors ahead of the service disconnect. A fusible safety switch can be installed up to 16.5 feet from the conductor point of connection to the service without overcurrent protection at splice point to service conductor.

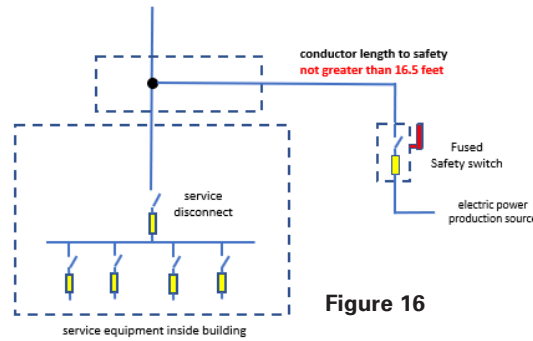

**Figure 16**

**Figure 17** illustrates compliance to 705.11(C)(2). In this case, the fusible safety switch can be up to 71 feet from the conductor splice point to the service conductors, if cable limiters are installed at the splice point to protect the electric production source conductors.

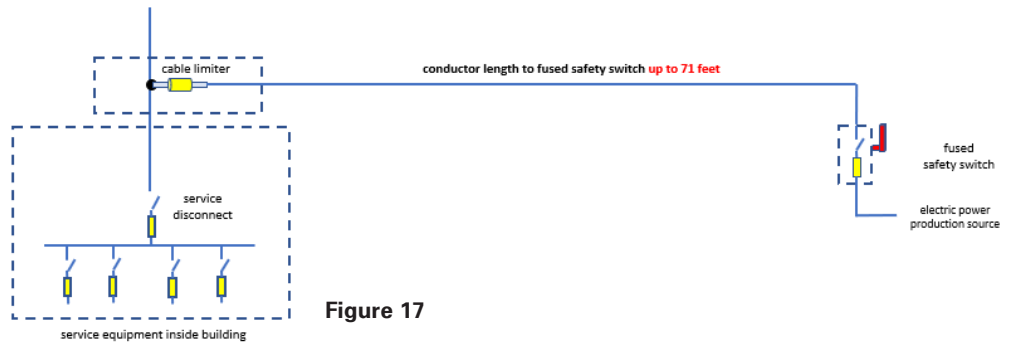

**Figure 17**

There may be other options to provide cable limiter protection for this application. For instance, in some cases, cable limiters can be installed on switchboard service terminations.

**Solution or products**

[\(See page 60 for product options\)](#)

Cable limiters are intended for isolating cables under short-circuit conditions. They are not intended for overload protection, which should be provided by branch-circuit rated fuses and circuit breakers. Cable limiters have high interrupting ratings and are current-limiting during short-circuit conditions.

Cable limiters are selected based on:

- Voltage rating - there are 250 V and 600 V cable limiters
- Conductor size - available for 12 AWG to 1000 kcmil cable
- Termination method - numerous termination types available
- Cu or Al conductors

Two basic applications:

- Multiple cables per phase (3 or more) - Cable limiter installed on both ends of cable
- One cable per phase - Cable limiter installed on source end of cable



Fusible safety switches with short-circuit current ratings of 200,000 A are available both in 250 V and 600 V ratings. It is recommended to specify and use safety switches that have fuse clips that only accept current-limiting fuses such as Class CF, Class R, and Class J fuses.

## 708.54 Selective Coordination

### Part IV Overcurrent Protection

#### Article 708 Critical Operations Power Systems (COPS)

##### Chapter 7 Special Conditions

REVISION

#### 708.54 Selective Coordination

Critical operations power system(s) overcurrent devices shall be selectively coordinated with all supply-side overcurrent protective devices.

Selective coordination shall be selected by a licensed professional engineer or other qualified persons engaged primarily in the design, installation, or maintenance of electrical systems. The selection shall be documented and made available to those authorized to design, install, inspect, maintain, and operate the system.

*Exception: Selective coordination shall not be required between two overcurrent devices located in series if no loads are connected in parallel with the downstream device.*

Informational Note: See Informational Note Figure 708.54 for an example of how critical operations power system overcurrent protective devices (OCPDs) selectively coordinate with all supply-side OCPDs. OCPD D selectively coordinates with OCPDs C, F, E, B, and A. OCPD C selectively coordinates with OCPDs F, E, B, and A. OCPD F selectively coordinates with OCPD E. OCPD B is not required to selectively coordinate with OCPD A because OCPD B is not a critical operations power system OCPD. Figure Informational Note Figure 708.54 Critical Operations Power System Selective Coordination.

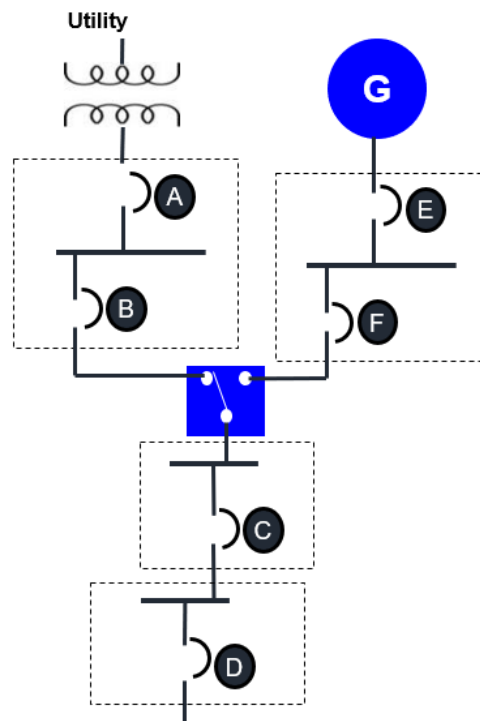

### Significance of the change

The new Informational Note and associated Informational Note Figure illustrate how the explicit language that each critical operation power system overcurrent protective device “shall be selectively coordinated with all supply-side overcurrent protective devices” is properly applied.

The burden is on each critical operation power system overcurrent protective device to selectively coordinate with:

- All supply-side critical operation power system OCPDs – these are OCPDs that are installed from the critical operation power system (COPS) alternate source to the COPS loads.
- All OCPDs installed in the current path from the normal source to the lineside of the COPS transfer switch.

Many people fail to recognize the subtlety of the COPS OCPDs being required to selectively coordinate with the OCPDs installed in the current path from the normal source to the transfer switch, which is:

- The COPS OCPDs must selectively coordinate with the OCPDs installed in the current path from the normal source to the transfer switch.
- However, an OCPD installed in the current path from the normal source to the transfer switch is not required to be selectively coordinated with any supply-side OCPD. Although not required, best engineering practice would be to have each normal source OCPD selectively coordinated with all supply-side normal source OCPDs.

#### Related NEC Sections

- Selective coordination definition
- 620.62
- 620.65
- 645.27
- 695.3(C)(3)
- 700.32
- 701.32

See more information in discussion on 700.32 change and selective coordination in the introduction of this publication.

### Change summary

- Informational Note and Informational Figure illustrate each critical operations power system OCPD must selectively coordinate with all supply-side critical operation power system OCPDs and all supply-side OCPDs in the normal source path to the legally required standby system.

# Bussmann series products



## LPJ-SP

600 V, 1 to 600 A  
time-delay Class J

Easily mounts in Class J holders, blocks and switches



## CUBEFuse

600 V, 1 to 400 A  
time-delay Class CF

Compact, finger-safe design mounts in holders and CCP\_CF switches



## LP-CC

600 V, up to 30 A  
time-delay Class CC

Small size, mounts in Class CC holders, blocks and switches



## KRP-C-SP

600 V, 601 to 6000 A  
time-delay Class L

Easily mounts in Class L blocks and switches



## JJS (300 V) and JJN (600 V)

1 to 1200 A (JJN) and 1 to 800 A (JJS), Class T



## LPS-RK-SP

600 V, 1/10 to 600 A  
Class RK1



## LPN-RK-SP

250 V, 1/10 to 600 A  
Class RK1



## CCP2-\_-30CC and CCP2-\_-CF

200 kA, 600 V  
UL Listed disconnects;  
Class CC and CF fuses up to 200 A



## RDF\_-\_-

200 kA, 600 V rotary disconnect switches for Class CC, J and L fuses up to 800 A



## Quik-Spec Coordination Panelboard



## Quik-Spec Power Module

Bussmann series Quik-Spec electrical gear makes compliance with SCCR requirements simple with 200 kA SCCR. It also makes it easy to meet selective coordination requirements with simple Low-Peak fuse 2:1 selective coordination ratios.

## Accessories



## CHCC and CH\_J

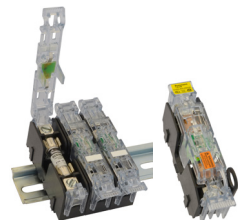

## TCF\_H

## RM\_-\_- JM60\_-\_-

Finger-safe fuse holders and blocks increase electrical safety

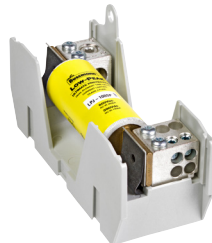

## JM600\_-MW\_-

200 kA SCCR, 600 V Class J ferrule and knifeblade modular power distribution fuse blocks up to 400 A (optional covers provide IP20 protection)



## PDBFS\_-

200 kA SCCR finger-safe, DIN-Rail mount 600 V modular power distribution blocks up to 760 A



## PDB\_-

200 kA SCCR panel mount 600 V power distribution blocks up to 760 A

**Notice:**

This publication has not been processed in accordance with NFPA® Regulations Governing Committee Projects. As such, it is not to be construed as an official posting of the NFPA or any of its committees, nor relied upon as a formal interpretation of the meaning or intent of any section of the 2020 edition of the NFPA 70 National Electrical Code (NEC®).

The reader is expressly warned to consider and adopt all safety precautions that might be indicated by the activities described herein and to avoid all potential hazards. By following directions in this publication, the reader willingly assumes all risks in connection with such directions.

Bussmann Division makes no representation of any kind, including but not limited to, the representation of fitness for particular purpose or merchantability, nor are any such representations implied with respect to the presented material. Eaton's Bussmann Division shall not be liable for any special, consequential, or exemplary damages resulting, in whole or in part, from the reader's use of, or reliance upon, this material.

Please refer to the NFPA 70 2020 NEC for complete information on the sections referenced in this publication.

Some photographs used in this publication were shot . Use of these photographs does not imply endorsement by Eaton's Bussmann Division of the depicted manufacturers' products.

This publication conveys information related to each of the Code changes it contains as of August, 2019, but does not reflect any subsequent appeal or action taken by the NFPA Standards Council.

©2019

Eaton's Bussmann Division

All rights reserved. No part of this work may be reproduced in whole or in part, in any graphic, electronic, or mechanical, including photocopying, audio or video recording form, or information storage and retrieval systems without the expressed written permission of the Bussmann Division.

**Eaton**

1000 Eaton Boulevard  
Cleveland, OH 44122  
Eaton.com

Bussmann Division  
114 Old State Road  
Ellisville, MO 63021  
United States  
[Eaton.com/bussmannseries](http://Eaton.com/bussmannseries)

© 2019 Eaton  
All Rights Reserved  
Printed in USA  
Publication No. 10970  
December 2019

Eaton, Bussmann, CUBEFuse, Low-Peak, Fusetron, Limitron, Quik-Spec and SAMI are valuable trademarks of Eaton in the US and other countries. You are not permitted to use the Eaton trademarks without prior written consent of Eaton.

CSA is a registered trademark of the Canadian Standards Group.  
NEC is a registered trademark of the National Fire Protection Association, Inc.  
NEMA is a registered trademark of the National Electrical Manufacturers Association.  
UL is a registered trademark of the Underwriters Laboratories, Inc.

For Eaton's Bussmann series product information, call **1-855-287-7626** or visit: **Eaton.com/bussmannseries**

Follow us on social media to get the latest product and support information.



**CHS Controls AB**

Tel +46 42 38 61 00, Fax +46 42 38 61 29  
[chs@chscontrols.se](mailto:chs@chscontrols.se) [www.chscontrols.se](http://www.chscontrols.se)